

RADIANT®

ARCHITECTURAL LIGHTING



# RADIANT®

## ARCHITECTURAL LIGHTING

Established in 2008 in London, Radiant Architectural Lighting provides bespoke, award-winning solutions for lighting designers on projects around the world.

Innovation is at the heart of Radiant's approach, with many of our 'standard' products originating from specific project requests.

Radiant's products are designed in collaboration with lighting designers and produced to the highest standards in the UK.

With a strong heritage in luminaire design, Radiant excels in designing interior and exterior lighting systems, giving our clients the tools they need to illuminate indoor and outdoor spaces perfectly.

Often you won't see our luminaires, which are designed to be discreet; what you will see are the astonishing lighting effects that serve to enhance beautiful architecture.

The highly experienced Radiant luminaire development team has designed a product portfolio which offers flexibility, adjustability and unrivalled performance. No matter how complex the project, Radiant is likely to be the perfect partner for your lighting requirements.

We operate in over 30 countries and our products can be found in buildings designed by world renowned architecture practices including Zaha Hadid Associates and Foster + Partners. We have produced lighting for The Royal Albert Hall in London, Geffen Hall in New York, the Heydar Aliyev Centre in Baku, and Strasbourg Cathedral in France.

# Guide

## Linear Lighting



### 3D LED Flex Systems

Page 1 - 4	3D LED Flex System Overview
Page 5 - 6	Circular economy approach
Page 7 - 8	3D LED Flex 200 System IP66
Page 9 - 14	3D LED Flex 100 System IP20 & IP66
Page 15 - 30	3D LED Flex 40 System IP20, IP66 & IP68
Page 31 - 36	3D LED Flex 25 System IP20, IP66 & IP68



### Other flexible linear systems

Page 37 - 41	Centura System IP20
Page 53 - 54	Euclid 20 Balljoint System IP20



### Linear systems

Page 42	Centura H System IP20
Page 43 - 44	F Grazer System IP20
Page 45 - 46	Shard System IP20
Page 47 - 48	Flaplight System IP20
Page 49	Flaplight Micro & Nano System IP20
Page 50	Euclid 12 System IP20
Page 51 - 52	Euclid 20 System IP20
Page 55 - 58	Euclid 30 System IP65 & IP68
Page 59 - 66	Euclid 40 System IP20 & IP66
Page 67 - 72	Euclid 60 System IP65 & In-Ground IP67
Page 73 - 74	Euclid 80 System IP65 & In-Ground IP67
Page 75 - 76	Euclid 100 System IP65
Page 77 - 78	Light Pipe System IP20

## Accent lighting



Page 79 - 80	Nano, Micro, & Macro Ribbed pendant System IP20
Page 81 - 82	Ovo pendant System IP20
Page 82 - 84	Micro Track System IP20
Page 85 - 87	D 100 and Aleta Projector Systems IP20
Page 89 - 90	Micro Spotlight System IP65
Page 91 - 92	D 100 Projector System IP66
Page 93 - 94	D 40 Projector System IP66
Page 95 - 96	Centura Module System IP20

## Effect lighting



Page 88	Stretta System IP20
Page 97 - 98	Water Effect System IP20 & IP65
Page 99 - 100	Water Effect In-Ground System IP65, and IP67
Page 101 - 102	Euclid 40 WE System IP20
Page 103 - 104	Euclid 40 WE ERLE System IP20
Page 105	Euclid 60 WE System IP65
Page 106	Colour Ray System IP20, IP66 & In-Ground IP67
Page 107	3D LED Flex 40 WE System IP 20
Page 108	D 100 WE Projector System IP20 & IP65
Page 109 - 110	D 200 WE Projector System IP20 & IP65

# 3D LED Flex System

## Ahead of every curve

The multi-award winning 3D LED Flex system has developed from a custom solution for a Zaha Hadid designed building into a comprehensive modular linear lighting system with a vast range of options.

Ideal for use in a wide range of interior, exterior and underwater lighting projects where curved lines of light are needed to illuminate non-linear building surfaces, columns and domes.

The patented mechanical joint structure allows the individual modules to be bent and twisted in three dimensions to follow complex building contours.



### 3D LED Flex 200 System

- Up to 12,000 Lumens per Mtr
- Up to 25W per 200mm module
- IP20, IP65 or IP66



### 3D LED Flex 100 System

- Up to 11,000 Lumens per Mtr
- Up to 11W per 100mm module
- IP20, IP65 or IP66



### 3D LED Flex 40 System

- Up to 5,000 Lumens per Mtr
- Up to 5W per 100mm module
- IP20, IP44, IP65, IP66 or IP68



### 3D LED Flex 25 System

- Up to 4,000 Lumens per Mtr
- Up to 4W per 100mm module
- IP20, IP65, IP66 or IP68



Heydar Aliyev Centre, Baku. Lighting design by MBLD

# 3D LED Flex System

Modular | Linear | 3D Flexible

- Flexible in 3-Dimensions - hand-bendable and lockable on-site.
- A range of sizes are available. Up to 12,000 lumens per mtr from the 200 size down to 4,000 lumens per mtr from the 25 size.
- IP ratings of IP20, IP44, IP65, IP66 and IP68 submersible.
- A wide range of LED light engine, reflector and lens options available. White light, RGB, RGBW, and dynamic white options available.
- Wide range of bracketry and anti-glare accessories. Custom lengths up to 2.5 mtrs based on a 100mm or 200mm module length.
- 5-year guarantee, with a refurbishment service thereafter. A modular, durable system with easily replaceable light-engines, designed to be refurbished and have a working life of up to 30 years.

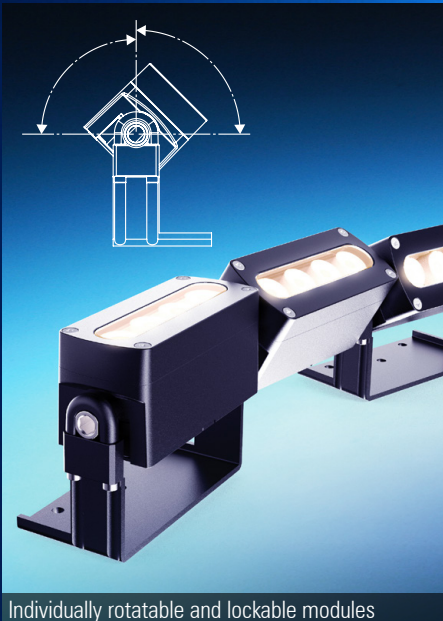
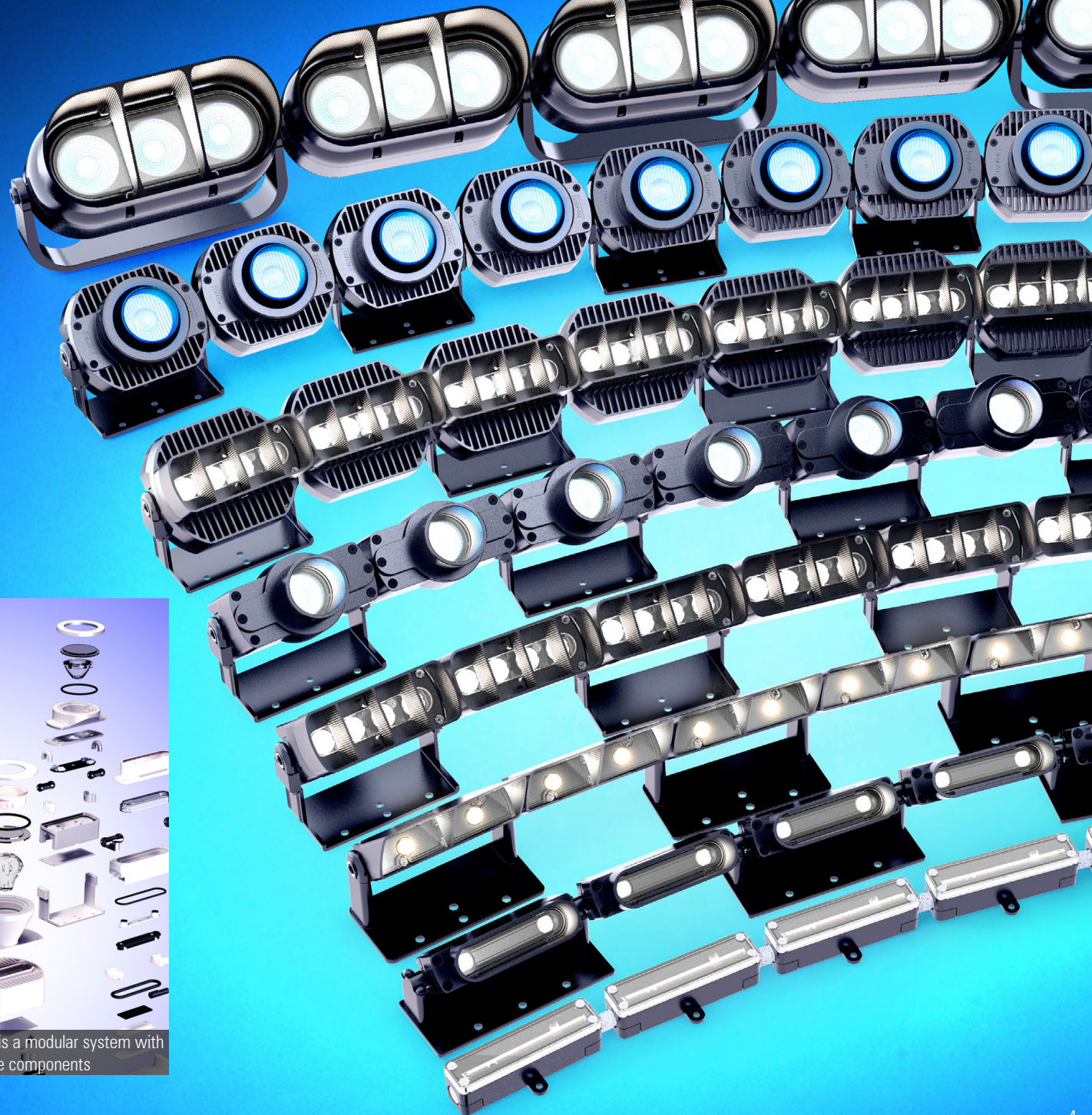

Individually rotatable and lockable modules



The 3D LED Flex System is a modular system with a vast array of compatible components

# Circular economy approach

Repair | Replace | Reuse

We aim for our systems to have a working life of up to 30 years.

Radiant is working to reduce the long-term environmental impact of its systems with a variety of approaches.

Radiant's award winning lighting systems have always been designed for efficient operation, longevity, ease of on-site repair, easy disassembly, refurbishment, rebuilding, and for eventual recycling of materials.

Using traditional construction methods allows Radiant systems to be easily disassembled and then reassembled into new products. Up to 95% of our cast, extruded, and moulded components can be reused indefinitely. We design our systems for a working life of up to 30 years including replacement of light engines and integral drivers.

Easy on-site replacement of light engines is a key element of the design of all new Radiant systems.

Working with partners in an increasing number of markets for local component production and system assembly will reduce the carbon generated by moving finished products around the world.

All Radiant systems come with a 5-year guarantee and we will provide a refurbishment and repair service thereafter to ensure that they operate efficiently for the longest possible time.

A TM 66 analysis of each Radiant system can be prepared for your projects.



With the Euclid 40 ERLE Systems, the rotational catches are turned using a flat-head screwdriver to lock and unlock the hinged side panels.

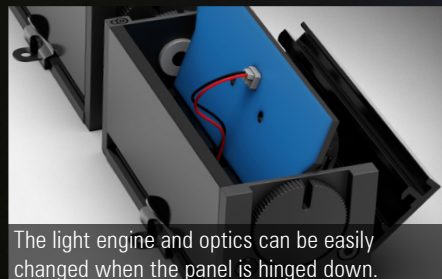
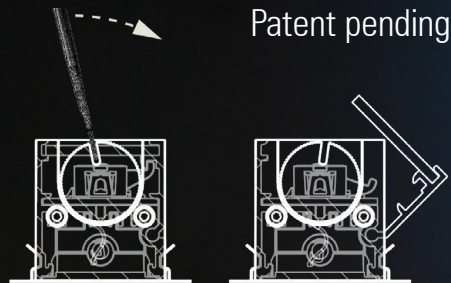

The light engine and optics can be easily changed when the panel is hinged down.

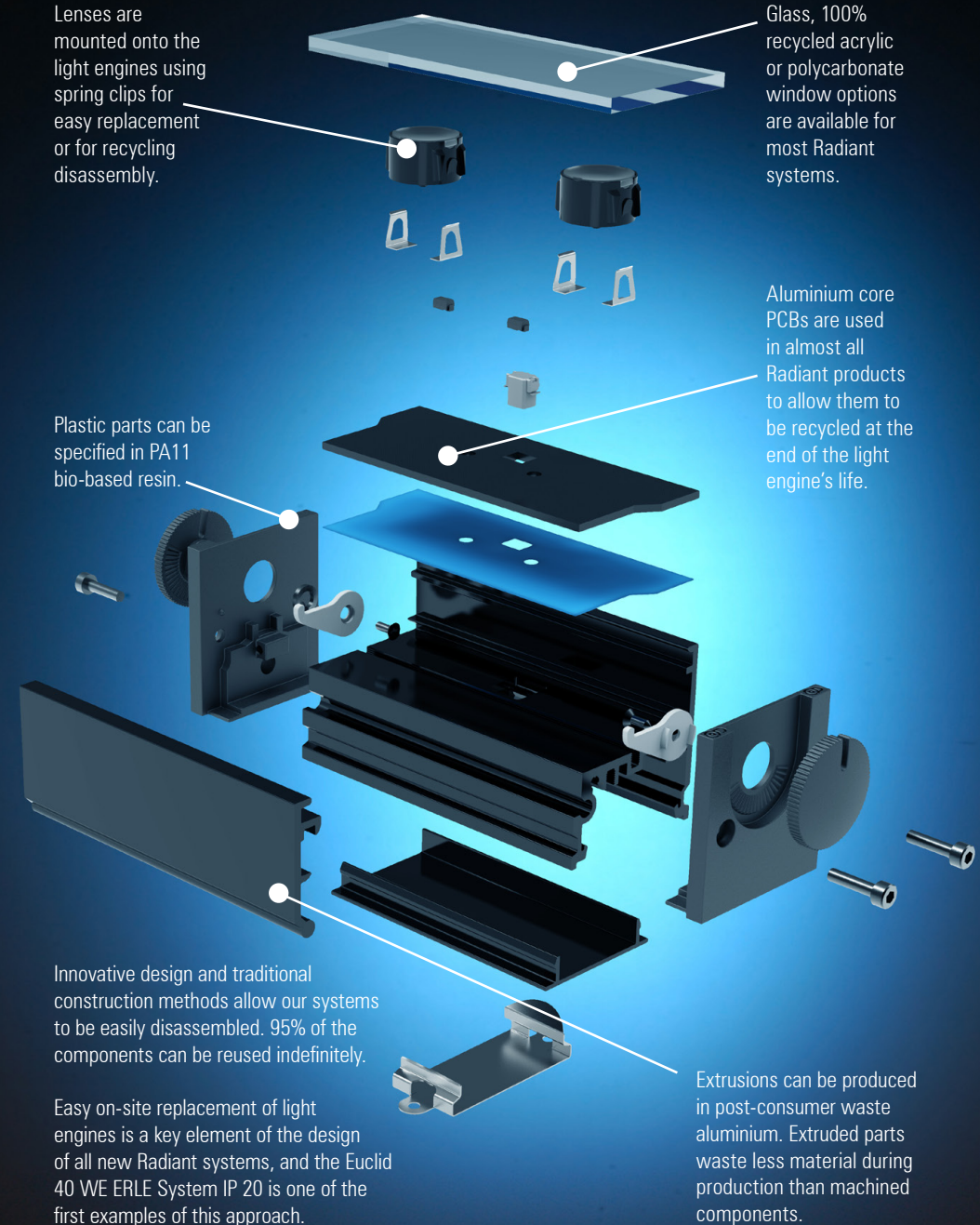

Lenses are mounted onto the light engines using spring clips for easy replacement or for recycling disassembly.

Glass, 100% recycled acrylic or polycarbonate window options are available for most Radiant systems.

Aluminium core PCBs are used in almost all Radiant products to allow them to be recycled at the end of the light engine's life.

Plastic parts can be specified in PA11 bio-based resin.

Innovative design and traditional construction methods allow our systems to be easily disassembled. 95% of the components can be reused indefinitely.

Easy on-site replacement of light engines is a key element of the design of all new Radiant systems, and the Euclid 40 WE ERLE System IP 20 is one of the first examples of this approach.

Extrusions can be produced in post-consumer waste aluminium. Extruded parts waste less material during production than machined components.

# 3D LED Flex 200 IP66

## Modular, 3D flexible LED exterior linear lighting system

The 3D LED Flex 200 IP66 system has been developed for use in a wide variety of large-scale exterior architectural lighting projects requiring wall grazing and wall wash lighting where the building surfaces are non-linear with curved profiles and facades. The patented articulated ball-joint system joining the heat-sink modules allows the system to follow complex curved building profiles.

The largest in the range, the 3D LED Flex 200 can be run at up to 125 Watts per mtr, providing up to 11,000 Lumens per mtr. Each 200mm long module comprises of 3 x arrays of 4 x RGBW Luxeon-Z LEDs with highly efficient Gaggione colour-blending lenses.

Integral AC to DC constant current drivers allow long lengths to be powered from a single power feed. Dimming interfaces include DALI, DMX, and 1-10V.

The system has minimal visible fixings and anti-glare snoots provide excellent glare control.

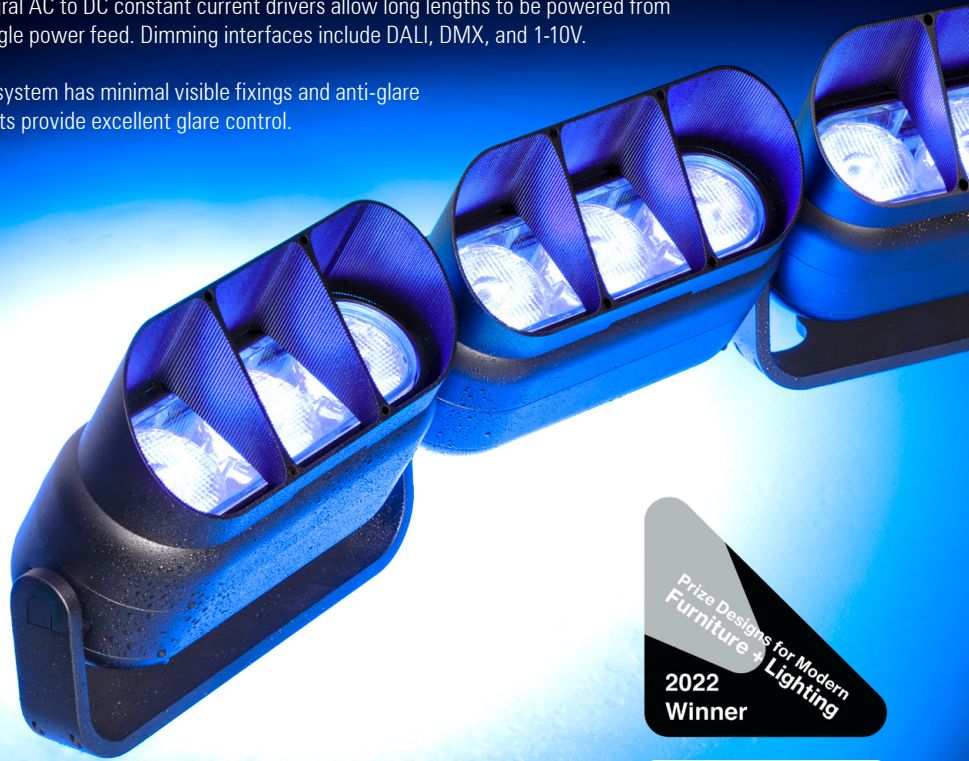

Up to 12,000 Lumens per mtr

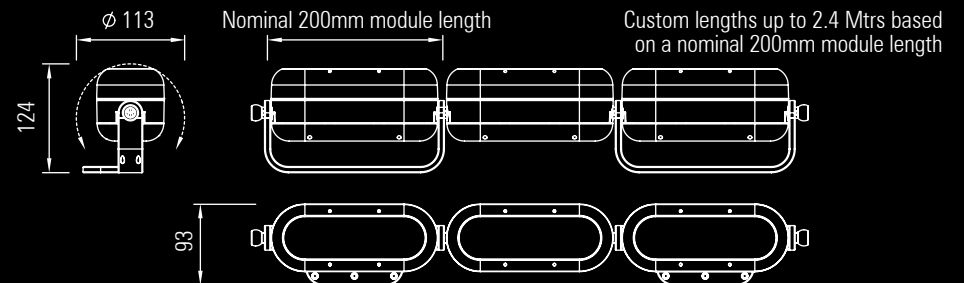

# 3D LED Flex 100 IP20

## Modular, 3D flexible LED interior linear lighting system

The Radiant 3D LED Flex 100 system was the first type in the range and was originally developed for the Heydar Aliyev Centre project to provide all the ambient lighting in the auditorium. The system has been further developed for use in a wide variety of other architectural lighting projects requiring cove lighting and wall wash lighting where the building surfaces are non-linear with curved profiles and facades.

The patented articulated joint system joining the heat sinks allows the system to follow curved building surfaces while maintaining a 25mm spacing between LEDs, thus ensuring continuous lit effects without shadows or dark areas.

Each LED heat sink module can operate up to 11 Watts of LEDs giving a light output of up to 11,000 lumens per mtr.

Integrated LV DC to DC constant current drivers allow long runs to be powered from a single remote power supply.



Up to 11,000 Lumens per mtr

Custom lengths up to 2.5 Mtrs based on a nominal 100 mm module length

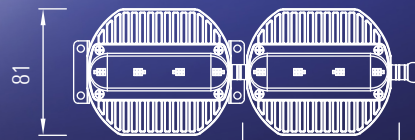
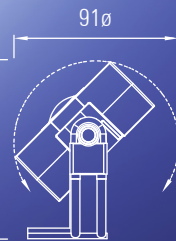

Nominal 100mm module length



Heydar Aliyev Centre  
Architect Zaha Hadid Associates  
Lighting design by MBLD

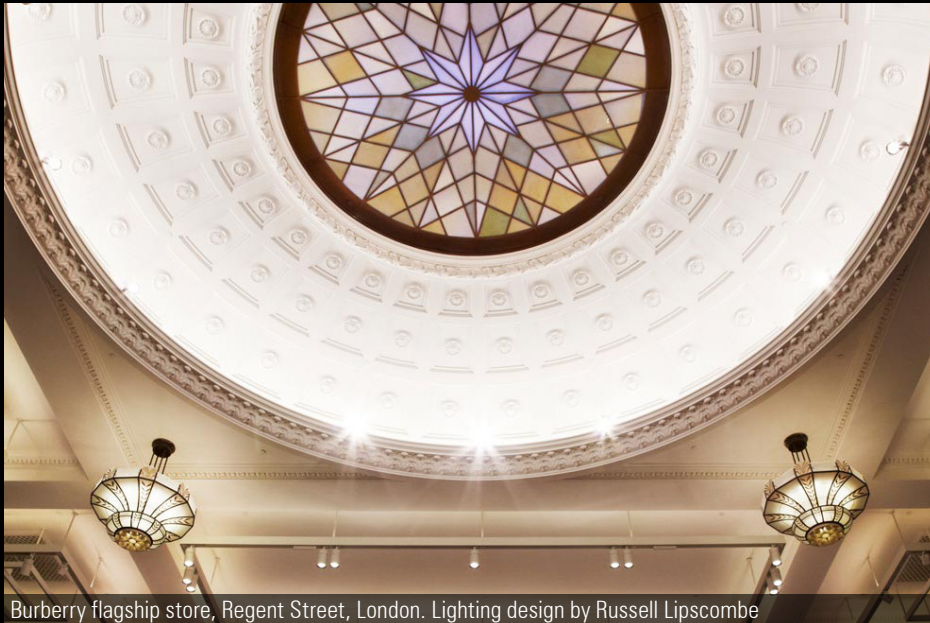

Burberry flagship store, Regent Street, London. Lighting design by Russell Lipscombe



Oman Across Ages Museum, Oman. Lighting design by DHA design. Project Image Credit: Squint/Opera



The McEwan Hall, University of Edinburgh. Lighting design by Buro Happold



Designer outlet, UK. Lighting design by Aecom



Mall of Oman. Lighting design by Aecom

## 3D LED Flex 100 IP66

### Modular, 3D flexible LED exterior linear lighting system

The Radiant 3D LED Flex 100 IP66 system has been developed for use in larger scale exterior lighting applications where the building surfaces are non-linear with curved profiles including columns, domes and curved facades.

The articulated joint system allows the LED heat sinks to follow three dimensionally curved surfaces while maintaining a 25 mm between LEDs, thus ensuring continuous lit effects without shadows or dark areas.

A digital thermal control system ensures that the LEDs work at an optimal temperature even in high ambients.



Up to 10,000 Lumens per mtr

**light AWARD**  
MIDDLE EAST WINNER 2018

**darc awards**  
WINNER 2018



The Lana, Dorchester Collection, Dubai. Lighting design by Light Touch PLD



Intu Lakeside Shopping Centre. Lighting design by Hoare Lea

# 3D LED Flex 40 IP20

Modular, IP20 3D flexible LED interior linear lighting system

The Radiant 3D LED Flex 40 IP20 system incorporates the widest range of versions and options and has been specified and installed on the greatest number of projects to date.

The system can be run at up to 50 Watts per mtr and provides over 5,000 lumens per mtr depending on LED colour temperature and type.

The system includes both interior IP20, exterior IP66 and underwater IP68 versions.



Up to 5,000 Lumens per mtr

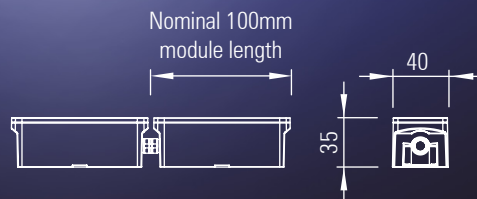

WestQuay Watermark, UK  
Lighting design by George Sexton Associates



Dior store, Riyadh. Lighting design by Metis lighting



3D LED Flex 40 IP20  
High-power LEDs with lenses



Amara Hotel, Cyprus  
Lighting design by Light 360



K11 Musea, Hong Kong. Lighting design by  
Speirs Major. Photography by Jackie Chan

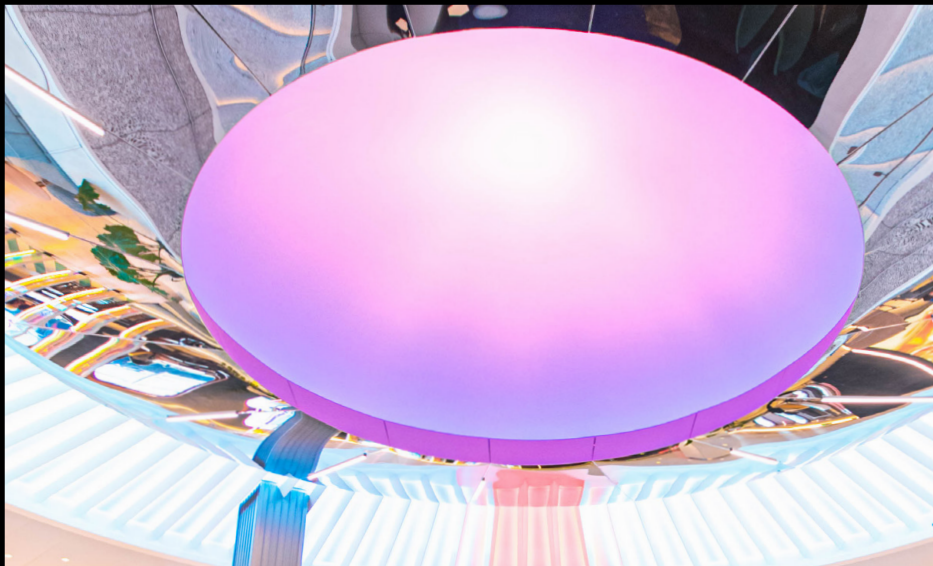

Virgin Voyages' Scarlet Lady cruise ship  
Lighting design by Cinimod. Project photography by Virgin Voyages



Hammersmith Apollo auditorium  
Lighting design by Jim Morse Lighting



Hammersmith Apollo foyer  
Lighting design by Jim Morse Lighting



3D LED Flex 40 IP20  
RGBW cluster array with Colour-mixing lens



3D LED Flex 40 IP20  
RGBW cluster array with mini Colour-mixing lens



3D LED Flex 40 IP20  
RGBW cluster array with asymmetric reflector

## 3D LED Flex 40 IP66

### Modular, IP66 3D flexible LED exterior linear lighting system

One of the early developments of the 3D LED Flex 40 system was an exterior IP66 rated version so that the same system can be used to light both interior and exterior projects. The system has also been used to light pools and hammams where high humidity would cause problems for an IP20 rated system.

The most popular elliptical optic version has been used to graze domes, curved roof surfaces and facades. The nominal 100mm module allows the system to be tailored to fit any building size and shape.

The system can be run at up to 50 Watts per mtr providing over 5,000 lumens per mtr. With many options for LED light engines, optics, mounting brackets and anti-glare accessories the system can be configured for each project.

A thermal control system is used in high ambient conditions to keep the LEDs working at an optimum temperature.



Up to 5,000 Lumens per mtr



University of Edinburgh Old College dome  
Lighting design by Nich Smith Lighting Design



The Bvlgari Spa, Dubai. Lighting design by Delta lighting solutions, Dubai  
Winner of the Light Middle East Award for Hotel Lighting Project of the Year



Deniz Mall, Baku, Azerbaijan  
Lighting design by MBLD



3D LED Flex 40 IP66 system. Each module comprises 4 x Luxeon Z red LEDs with a Gaggione ultra-narrow beam lens, and custom height anti-glare snoot. Each module is individually addressable via DMX

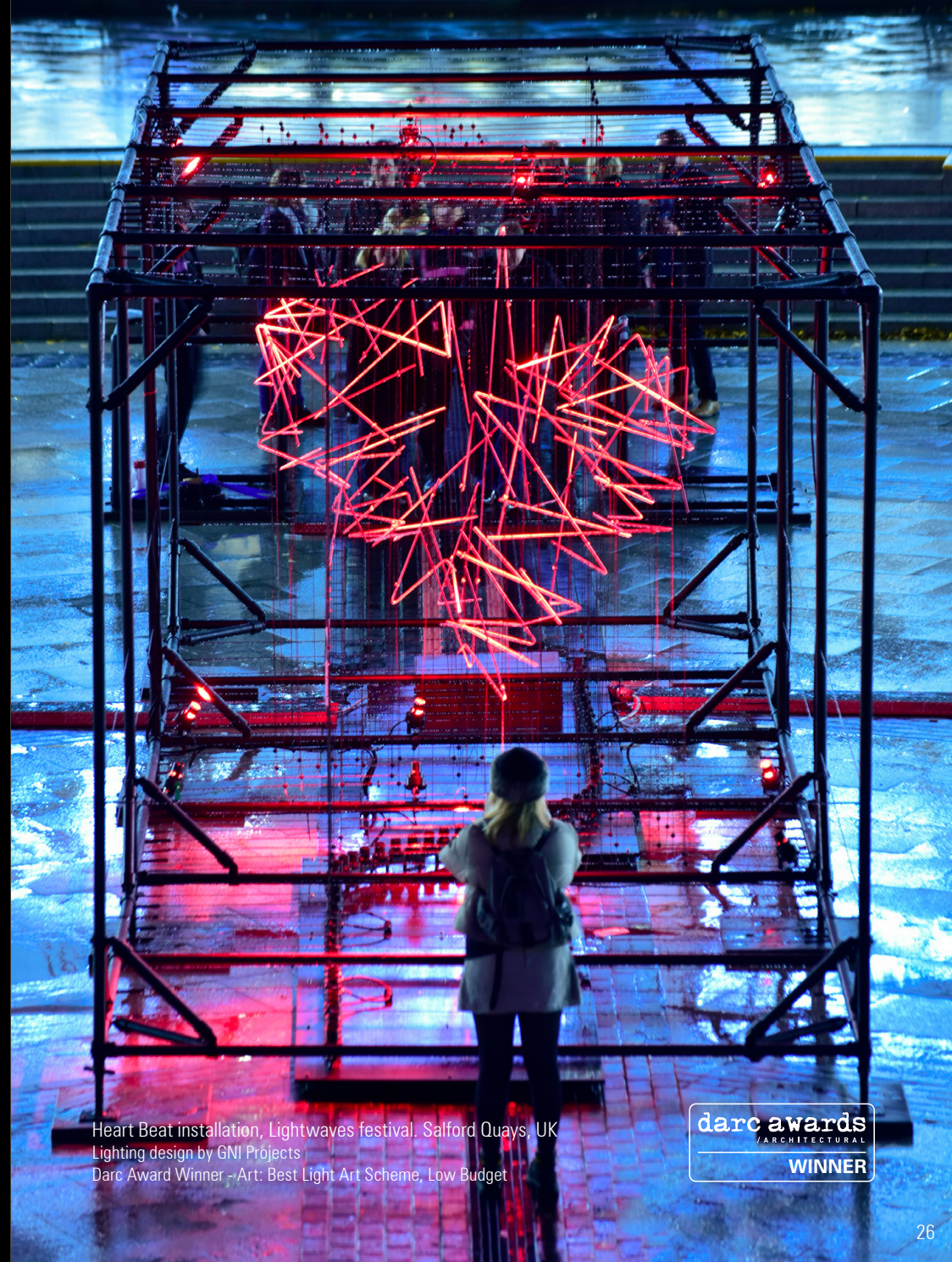
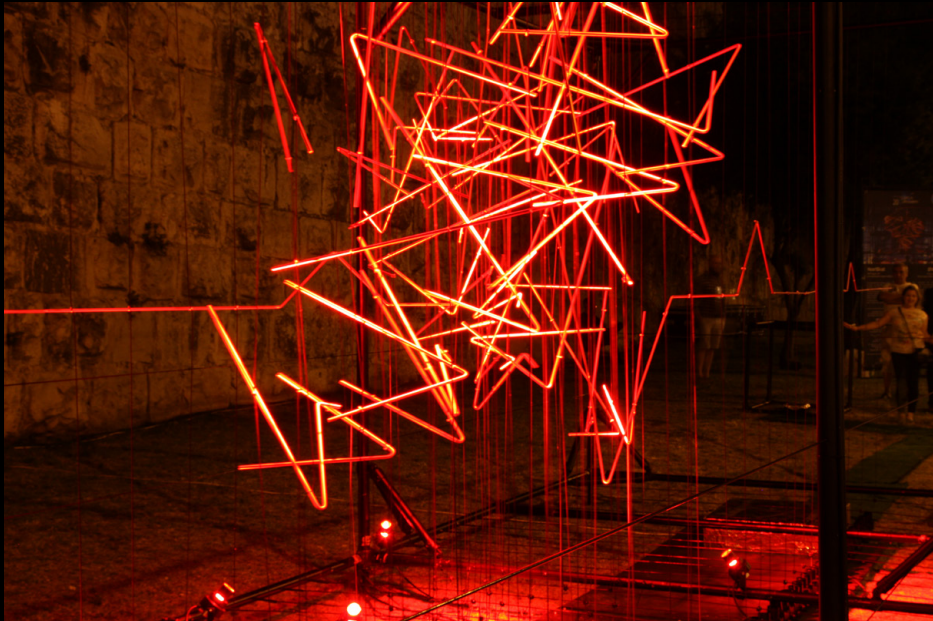

Heart Beat installation, Lightwaves festival. Salford Quays, UK  
 Lighting design by GNI Projects  
 Darc Award Winner - Art: Best Light Art Scheme, Low Budget





3D LED Flex 40 System IP66 RGBW - 200 mm module pitch  
Each module is individually addressable via DMX



8 or 12 x 0.3 Watt medium power LEDs with white reflector per module



1 x RGBW array with reflector per module



4 x high power LEDs with lenses per module

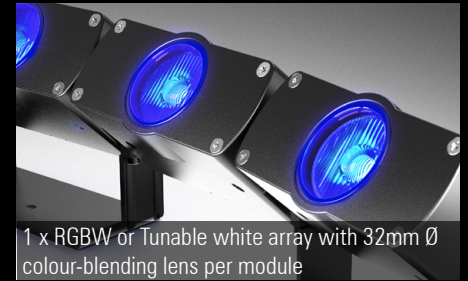

1 x RGBW or Tunable white array with 32mm Ø colour-blending lens per module



1 x high power LED with ultra-narrow beam lens per module

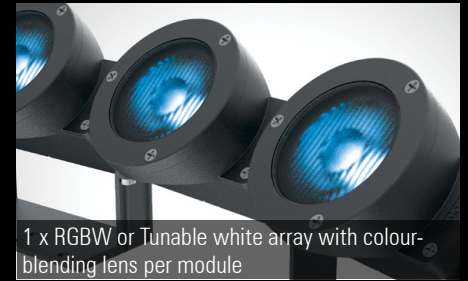

1 x RGBW or Tunable white array with colour-blending lens per module



South Devon College, UK. Lighting design by Michael Grubb Studio. Photograph by Tom Davey

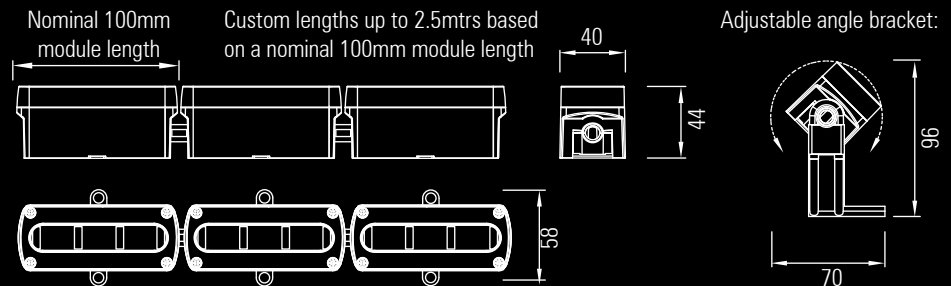

# 3D LED Flex 40 IP68

## Modular, IP68 3D flexible LED underwater linear lighting system

The Radiant 3D LED Flex 40 IP68 system is designed for use in underwater applications where curved lines of light are required. The system components are cast in 316 L stainless steel and are suitable for use in saline and chlorine environments including pools, fountains and marine projects. The pressed glass windows are bonded to the module bodies and all LED and internal driver boards are potted in silicone resin to ensure long working life at up to 2 mtrs depth.

The patented articulated joint system joining the LED modules allows the system to bend and twist in three dimensions to follow curved building surfaces while maintaining a constant spacing between LEDs. Output up to 4,000 lumens per mtr.

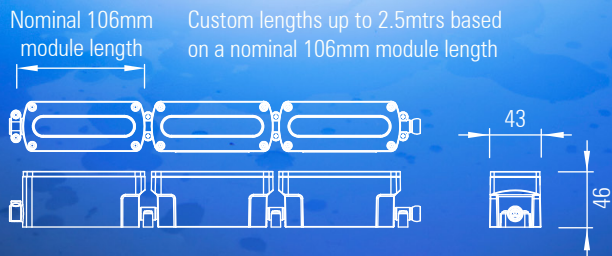

Up to 4,000 Lumens per mtr

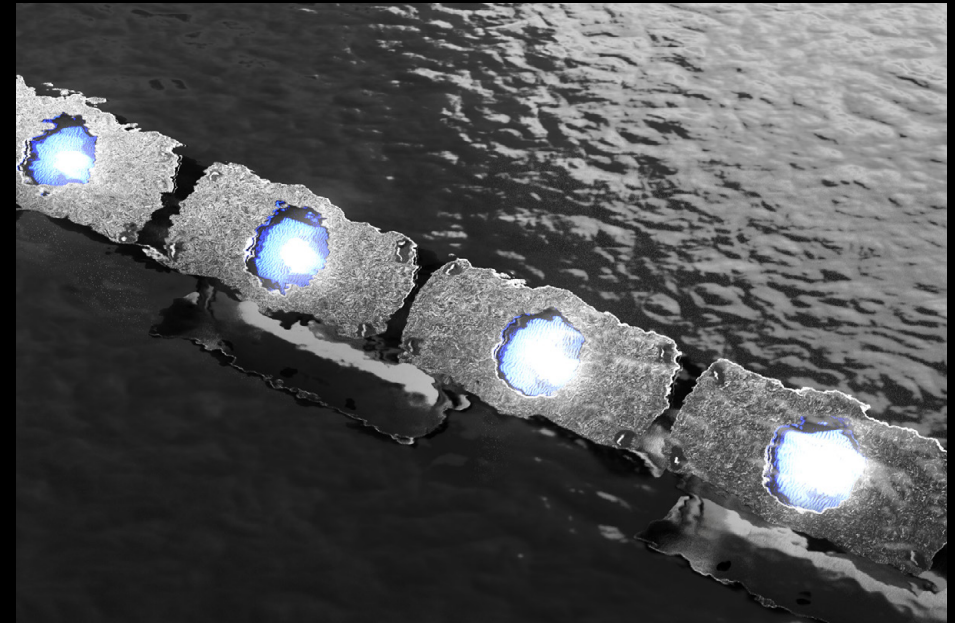

3D LED Flex 40 IP68 RGBW or Tunable white with mini 32 mm diameter colour-blending Gaggione lenses

# 3D LED Flex 25 IP20

## Modular, 3D flexible LED interior linear lighting system

The Radiant 3D LED Flex 25 system incorporates many of the design features of the 100 and 40 systems but with a smaller width of only 25 mm.

The system is ideal for use in smaller architectural, retail and hospitality lighting applications.

This is the most cost effective version of the 3D LED Flex range and has a light output of up to 4,000 lumens per mtr.

Like the larger sizes, the 25 system is available with a wide range of light engines, optics, dimming interfaces, anti-glare accessories and mounting bracketry to suit each project.

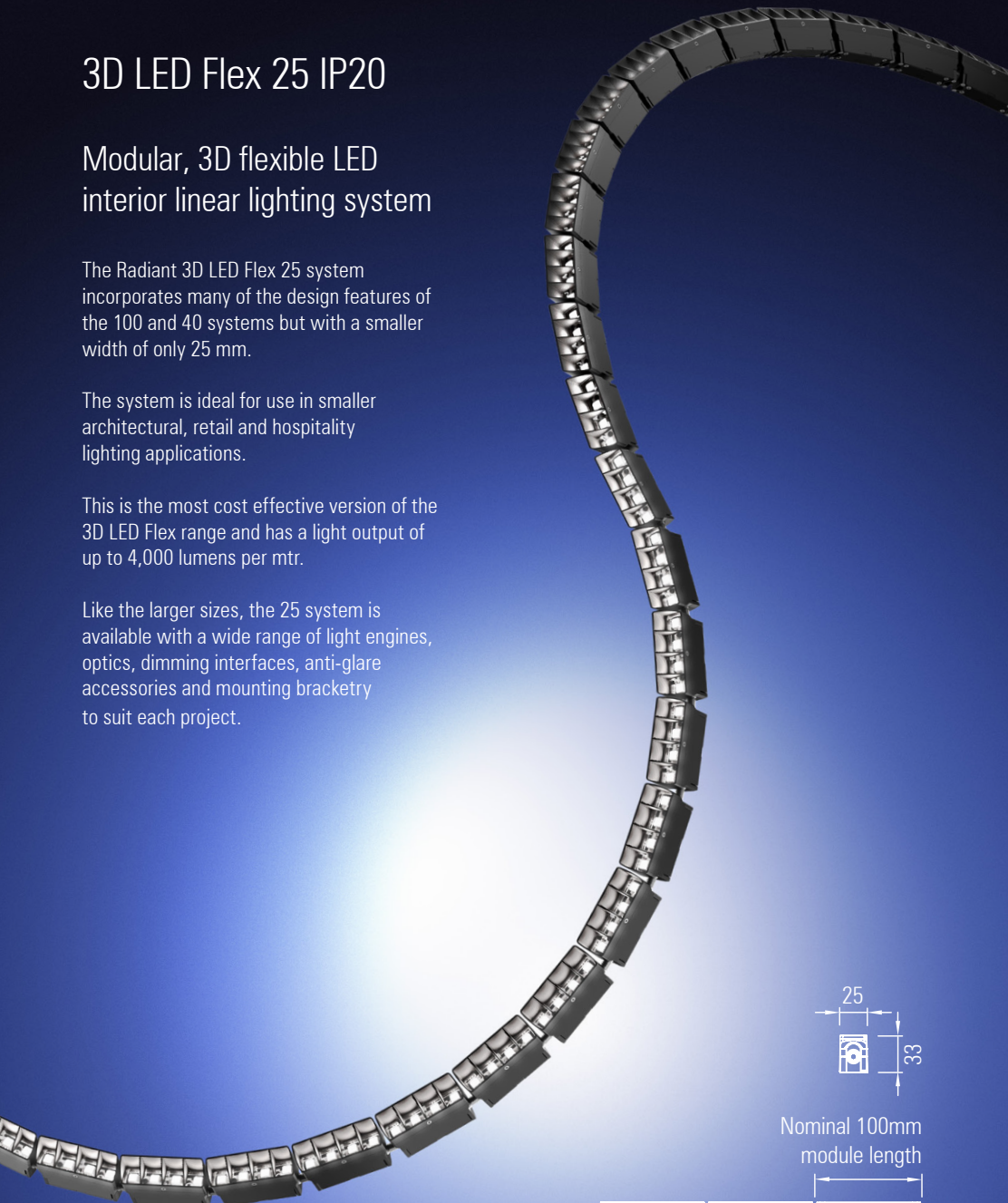

Up to 4,000 Lumens per mtr

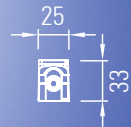

Nominal 100mm module length



Chartered Accountants' Hall, One Moorgate Place, London. Lighting design by Nulty Project image © provided by One Moorgate Place



Sydney Lyric Theatre, Australia. Lighting design by Schuler Shook



680 Folsom Street, San Francisco, USA Lighting design by Schuler Shook

# 3D LED Flex 25 IP66

## Modular IP66 3D flexible LED exterior linear lighting system

The Radiant 3D LED Flex 25 IP66 system is designed to be used in a wide variety of exterior lighting applications where a lower light output and smaller width is needed than the larger types also available in the range.

The system is ideal for use in smaller architectural and facade lighting applications. The system is available in a wide variety of LED, lens and reflector options and can be supplied with pressed glass windows for use in high sunlight situations or where sand abrasion is an issue.

A thermal control system is used in high ambient conditions to keep the LEDs working at an optimum temperature.



Custom lengths up to 2.5mtrs based on a nominal 100mm module length



Up to 4,000 Lumens per mtr



Royal Albert Hall, London. Lighting design by E02 Light

# 3D LED Flex 25 IP68

## Modular IP68 3D flexible LED linear lighting system

The Radiant 3D LED Flex 25 IP68 system is designed for underwater applications where the building surfaces are non-linear with curved profiles. The articulated joint system joining the LED heat sinks allows the system to follow curved building surfaces while maintaining a constant spacing between LEDs, thus ensuring continuous lit effects without shadows or dark areas.

The system is submersible up to 2 mtrs. The system components are cast in 316 L stainless steel and are suitable for use in saline and chlorine environments including pools, fountains and marine projects. Each module incorporates two Cree XPE LEDs with or without lenses.

The system can be run at 25 Watts per mtr and provides up to 2,500 lumens per mtr.

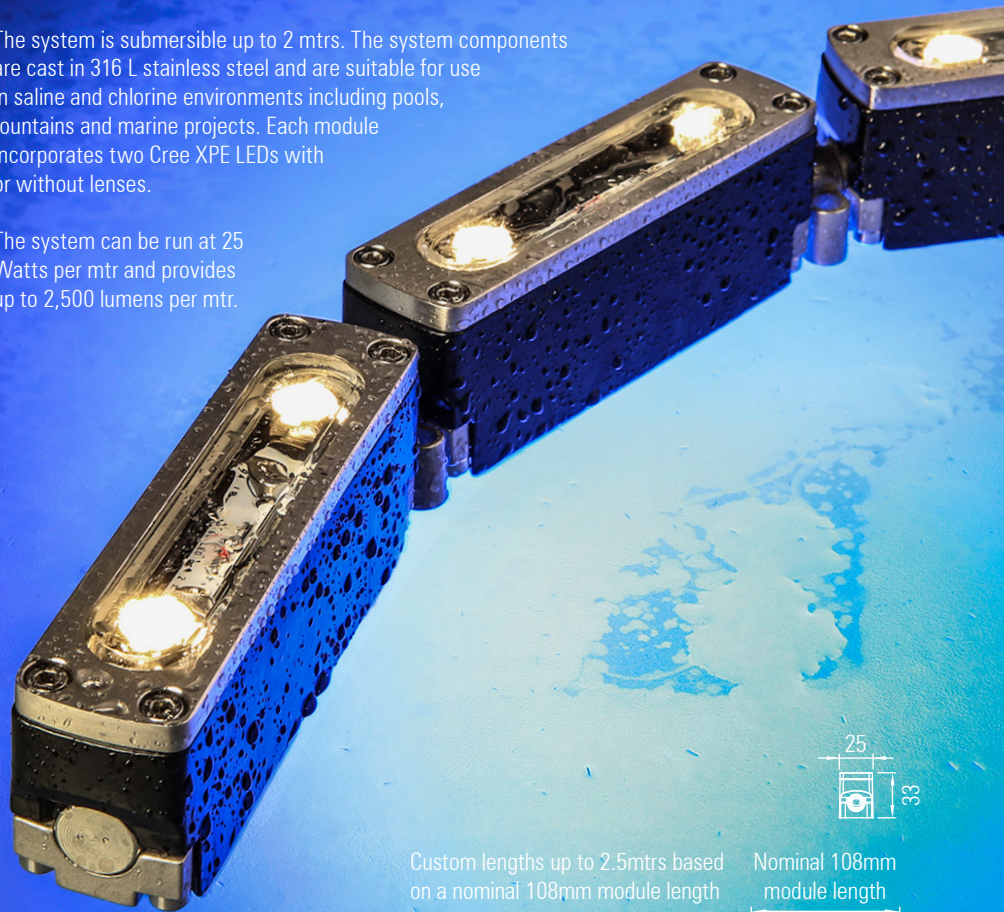

Custom lengths up to 2.5mtrs based on a nominal 108mm module length

Nominal 108mm module length



Up to 2,500 Lumens per mtr

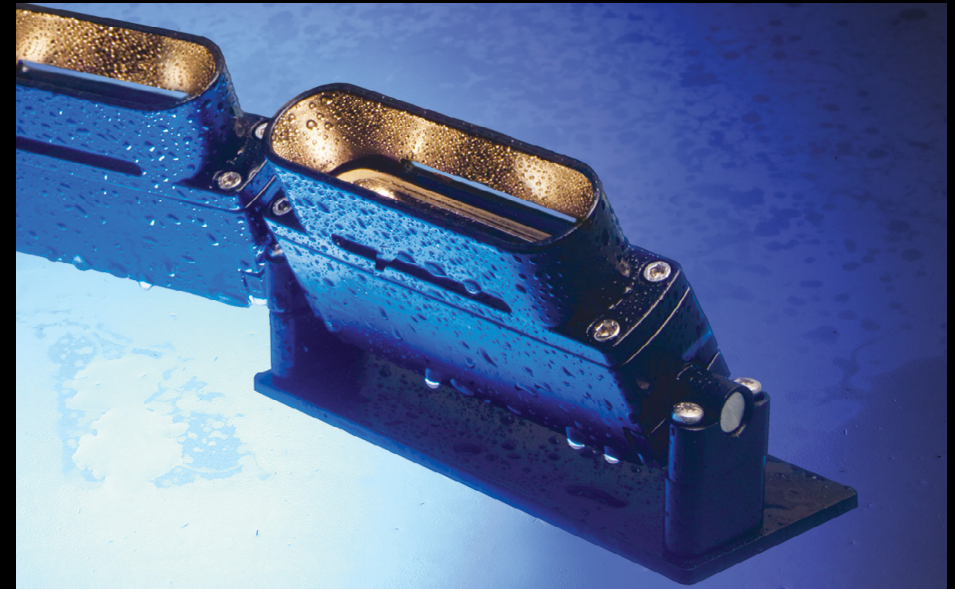

3D LED Flex 25 IP68 with adjustable angle brackets and anti-glare snoot accessory



Chanel Spa at the Ritz Hotel, Paris. Lighting design by Schwinghammer Lighting Design, New York

# Centura IP20

## Modular, interior, flexible, linear LED pendant system

Centura is a flexible LED interior linear lighting system, designed to make complex designs simple. An innovative design offers the flexibility to follow curved surfaces, encircle columns and domes, and to make irregular shaped pendants, all whilst offering excellent lighting control and uniformity.

The system is available in uplight and downlight and aimable side accent-light solutions, surface mounted or suspended, and with a light output of up to 6,500 lumens per mtr, making it ideal for a wide range of application areas including architectural, hospitality, leisure and retail.

The body and anti-glare louvres are available in all RAL colours, including gold for warmth, black for a dark light effect and red for dramatic impact.

In addition to the original Centura 40 System, with a module length of 100mm and width of 40mm, the Centura 40 150 System has a module length of 150mm, whilst maintaining the 40mm module width.

The Centura 60 System, with a module length of 100mm and width of 60mm, incorporates high-efficiency Gaggione colour-blending lenses and is designed for applications where highly-controlled RGBW or Tunable-white lighting effects are required.

Up to 6,500 Lumens per mtr

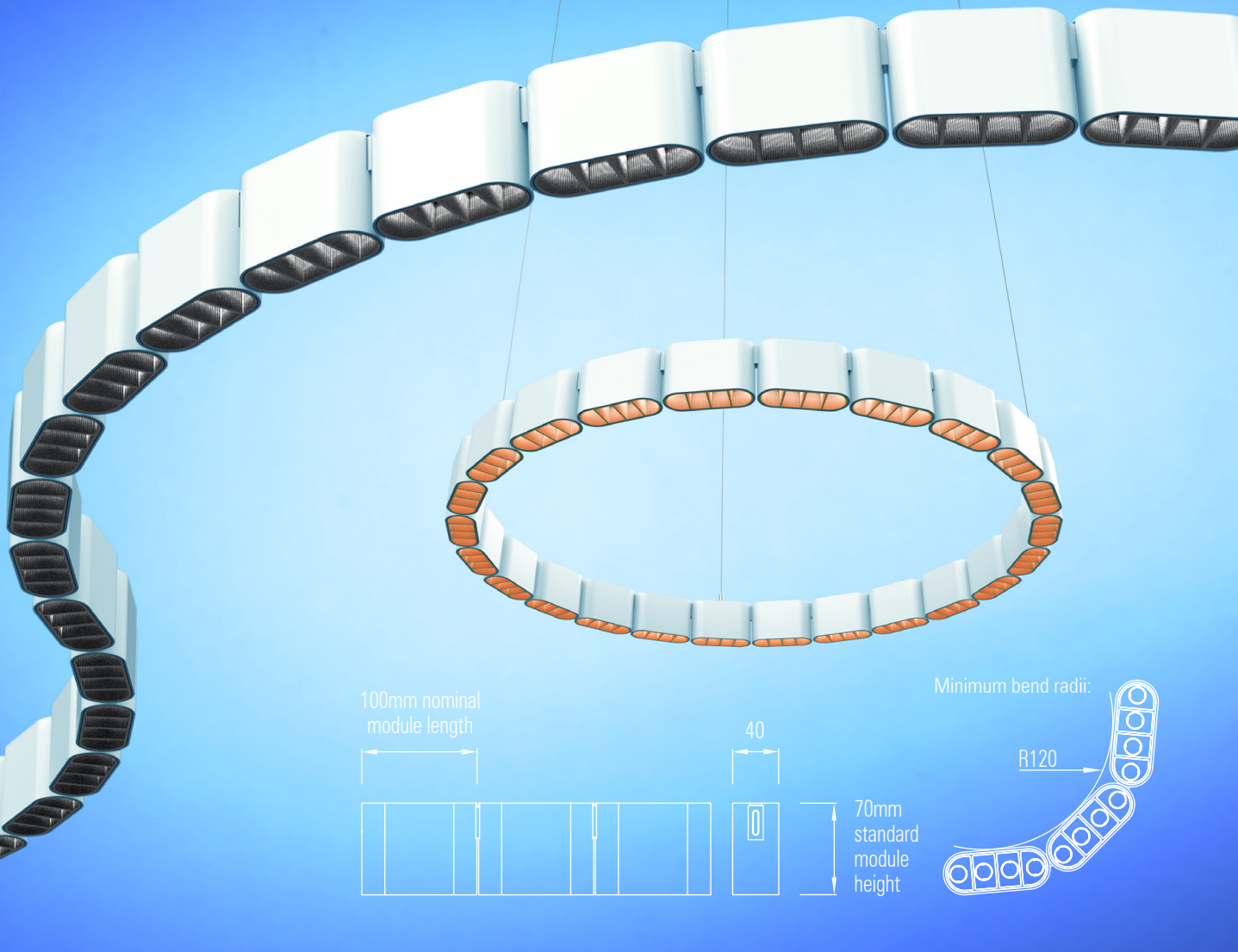

100mm nominal module length

40

Minimum bend radii:

R120

70mm standard module height

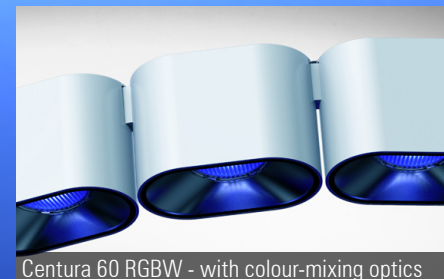

Centura 60 RGBW - with colour-mixing optics



Centura 40 150 IP20 - with opal diffuser



Freshfields Bruckhaus Deringer, London. Lighting design by 18 Degrees



33 Wigmore Street, London  
Lighting Design by Syntax Lighting

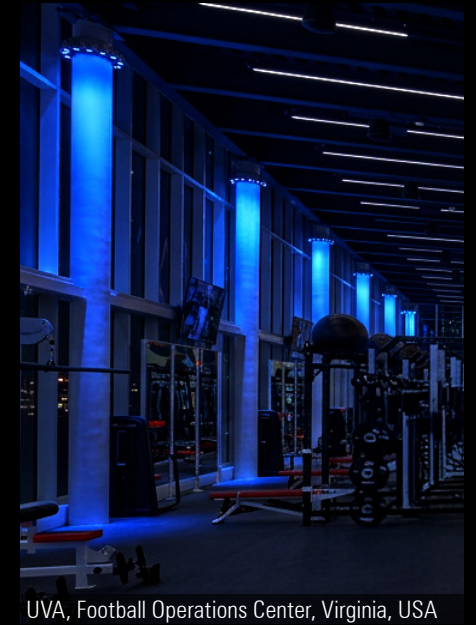

UVA, Football Operations Center, Virginia, USA



Bischöfliches Schloss Rittersaal Switzerland. Lighting design by Michael Josef Heusi. © Ralph Feiner



Wimpole Street Dental Clinic, London

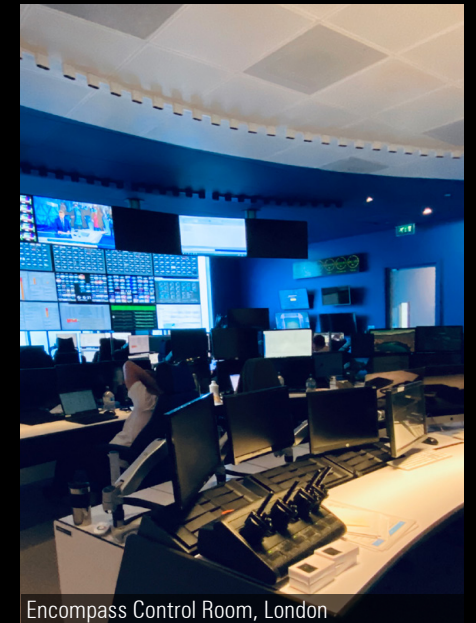

Encompass Control Room, London

## Centura V System IP20

### Modular, flexible, interior linear LED pendant system

The Centura V is a linear system that links directly to the flexible-linear Centura 40 150 and Centura 40 systems, to provide continuous runs of straight and curved illumination with a matching appearance and the same light engines, optics and louvres.

The system can provide direct downlight, direct uplight and combinations of both distributions in one luminaire.

The system has integral LV constant current drivers and the luminaires can be joined together on site with through wiring to provide long lines of light from a single feed point.

Dimming options include 1 - 10V, DMX and DALI with one dimming kit able to control up to 400 Mtrs of the system. The Centura light engines offer a wide variety of outputs and distributions.

The system is available in surface mount or suspended pendant formats, making it ideal for a wide range of application areas including architectural, hospitality, leisure and retail.

Powder coat and anodised finishes can be customised to meet project requirements. The decorative anti-glare louvred snoots can be specified in custom powder coat or anodized finishes. The outer body finish can be specified to any RAL powder coat finish.

Up to 6,500 Lumens per mtr

## Centura H System IP20

### Modular, interior linear LED pendant system

The Centura H linear system can provide direct downlight, direct uplight and combinations of both distributions in one luminaire. The luminaires can be joined together on site with through wiring to provide long lines of light from a single feed point. The Centura light engines offer a wide variety of outputs and distributions.

Powder coat and anodised finishes can be customised to meet project requirements. The decorative anti-glare louvred snoots can be specified in custom powder coat or anodized finishes. The outer body finish can be specified to any RAL powder coat finish.

The system is available in surface mount or suspended pendant formats, with a light output of up to 6,500 lumens per Mtr, making it ideal for a wide range of application areas including architectural, hospitality, leisure and retail.

The system has integral LV constant current drivers, so long lengths can be lit from a single large remote power supply unit. Dimming options include 1 - 10V, DMX and DALI with one dimming kit able to control up to 400 Mtrs of the system.

The Centura H linear system incorporates the same light engines and LV DC to DC dimmable drivers as the flexible linear Centura 40 and Centura 40 150 systems, allowing them to be used in conjunction in the same projects.

Up to 6,500 Lumens per mtr

# F Grazer IP20

## LED interior linear lighting system

The F Grazer system has been developed for use in hospitality lighting projects, to produce surface grazing effects where a minimal and cost-effective solution is required. In its simplest form the 330 mm light engine modules, complete with narrow elliptical lenses, are combined with the extruded body heat sink to provide an efficient concealed grazer luminaire. Direct fixing through the heat sink extrusion.

Glare control louvres, optical film diffusers, clear covers and end caps can be added to create a fully featured linear lighting system. A self-locking adjustable angle version is also available.

On board constant current linear drivers ensure the tightly binned LEDs are run at the optimum drive current.

Up to 10 mtrs of the system can be run from a single remote LV power supply. Dimming is via a separate pwm channel with an interface to all standard dimming systems.

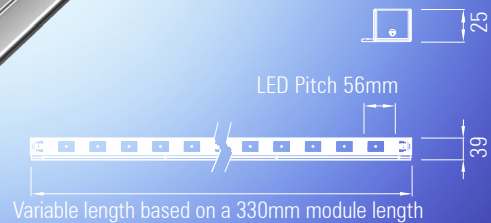

Up to 2,000 Lumens per mtr

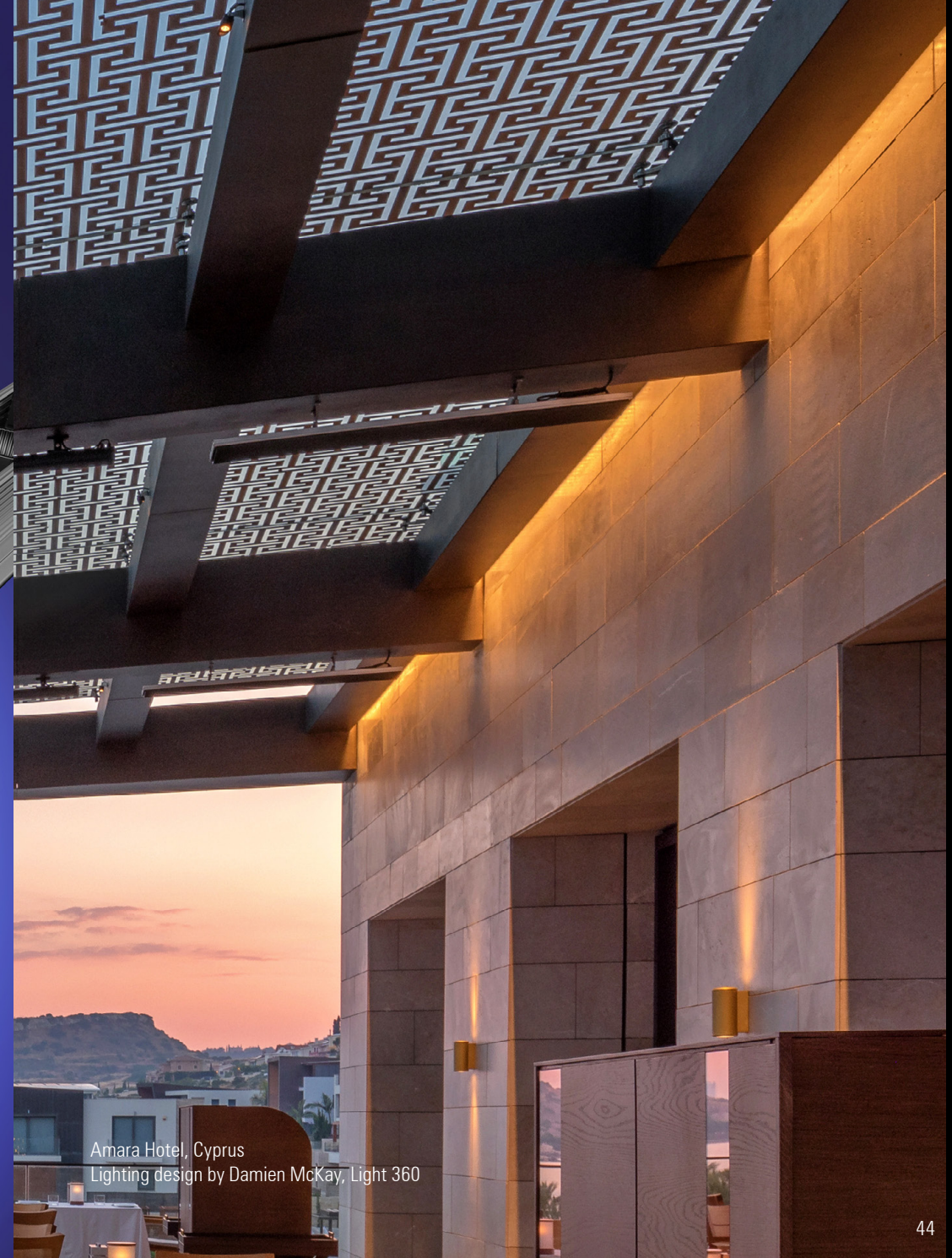

Amara Hotel, Cyprus  
Lighting design by Damien McKay, Light 360

## Shard undercabinet IP20

### LED interior linear lighting system

The Shard linear lighting system was developed with George Sexton Associates for use in the apartments of the iconic Shard building in London.

The system incorporates medium power LED light engines, with on board linear drivers, in a wide variety of colour temperatures with CRI up to 95. Up to 1,500 lumens per mtr. Dot free opal or clear window versions are available.

The system can be supplied in any length up to 2.5 mtrs. Smallest cutting module based on 100mm LED pitch. Longer continuous runs plug together on site.

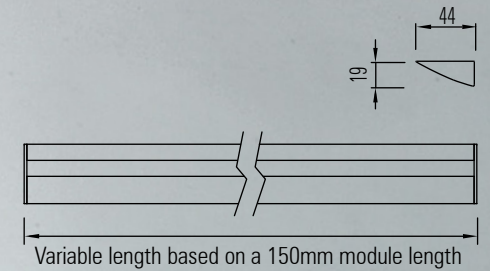

Up to 1,500 Lumens per mtr

# Flaplight IP20

## LED interior linear display lighting system

The Radiant LED Flaplight system incorporates lockable, hinged barn-door flaps to control glare and cut-off.

The Flaplight System can be configured as a picture-light, pendant, task-light, vertical free-standing luminaire, or a flexible-linear system.

With the flexible version, a series of custom-length Flaplight modules are linked with our patented friction ball-joints, allowing for 3-dimensional flexibility.

The system has been developed for a wide variety of linear display lighting applications including museums, galleries and retail.

The lighting head can be fitted with a variety of lenses to control the beam angle.

A wide range of Anodized and powder-coat finishes are available.

Bracketry and luminaire lengths can be customised to suit project requirements. The flaps and body can be locked at the correct aiming angle.

Integral LV constant current drivers are dimmable with all systems.

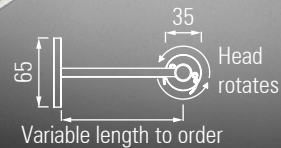

Up to 3,000 Lumens per mtr



The barn-doors control glare and cut-off



3D-flexible linear configuration

## Flaplight Micro and Flaplight Nano IP20

### LED interior linear display lighting system

The Radiant Micro and Nano Flaplight systems extend the range with smaller sizes suitable for use in residential projects and within display cases.

The Micro incorporates the same lockable, hinged barn-doors as the standard size Flaplight.

The Nano has fixed flaps to give excellent glare control and visual comfort in the smallest overall size.

The smaller systems incorporate a linear lens for excellent beam control or for a softer diffuse lit effect.

Nano: Up to 1,500 Lumens per mtr  
Micro: Up to 2,500 Lumens per mtr

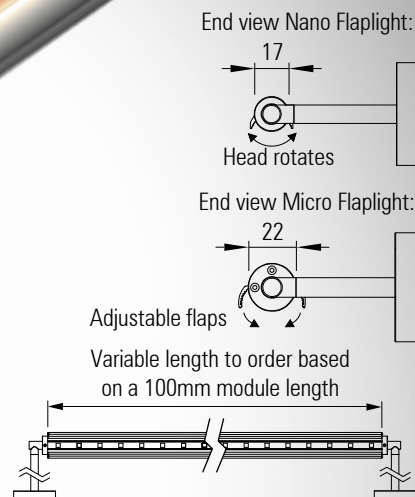

## Euclid 12

### LED linear lighting system

The Euclid 12 system was developed with George Sexton Associates as a custom design for a major residential lighting project.

The smallest section linear system in the Radiant range, the Euclid 12 can provide up to 800 lumens per mtr.

The system incorporates the same medium power LED light engines used in the Shard so that the two systems can be used together. On board linear drivers and LEDs in a wide variety of colour temperatures with CRI up to 95.

Linear COB options are also available, allowing for dot-free linear lighting.

Opal or clear window versions are available.

The system can be supplied in any length up to 2.5 mtrs. Smallest cutting module based on 100 mm LED pitch.

Up to 800 Lumens per mtr



# Euclid 20 Standard and High Output

## LED interior linear lighting system

The Euclid 20 system was originally developed with DPA in Dubai for use on residential projects as a simple to install, cost effective linear lighting system. The 16 Amp plug together connector system, which fits inside the body extrusion, allows up to 30 ft to be lit from a single feed point without dark gaps between strips.

Designed for use in both indirect cove lighting applications and also, with the addition of a linear lens and optical films, for wall grazing and wall washing.

The system incorporates the same medium power LEDs used in the Shard and Euclid 12 so that all these systems can be used together. Up to 1000 lumens per ft for the high output version. Clear window, Opal and Dot free opal and clear are available along with RGBW and dynamic white light versions.

The system can be supplied in any length up to 8.3 ft with the smallest cutting module based on 4" LED pitch.

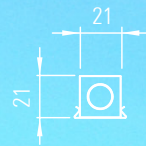

Up to 3,500 Lumens per mtr

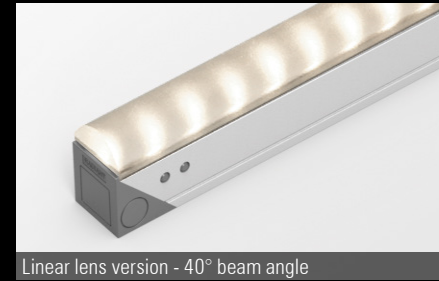

Linear lens version - 40° beam angle

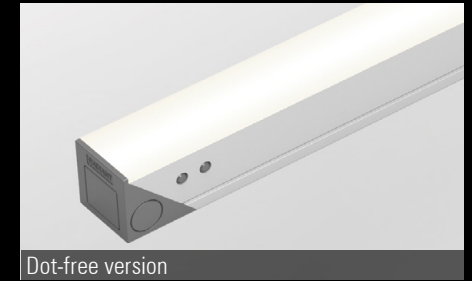

Dot-free version

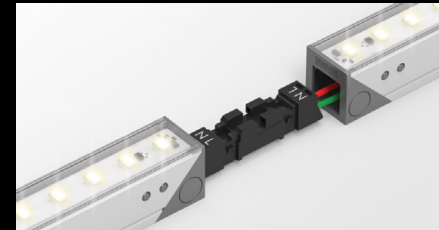

Plug together 16 Amp connector between strips. Connector fits inside modules for continuous lighting



Euclid 20 side feed



London Heathrow Airport, Terminal 2. Lighting design by Studio Fractal and Hoare Lea. Lux Award winner

# Euclid 20 Balljoint Standard and High Output IP20

## Modular, interior, 3D flexible LED linear lighting system

The Euclid 20 Balljoint system combines the simplicity of the Euclid 20 with the total flexibility of the 3D LED Flex range.

The system incorporates the same medium power LEDs used in the Euclid 20 so that these systems can be used together on the same project. On board linear drivers and LEDs in a wide variety of colour temperatures with CRI up to 95. 3,500 lumens per mtr for the high output version. Opal, Dot free opal, clear window and linear lens versions are available.

Modules in any length based on a 100 mm module can be used to make up complete lengths of the system. RGBW and dynamic white light engines can also be incorporated in this system.

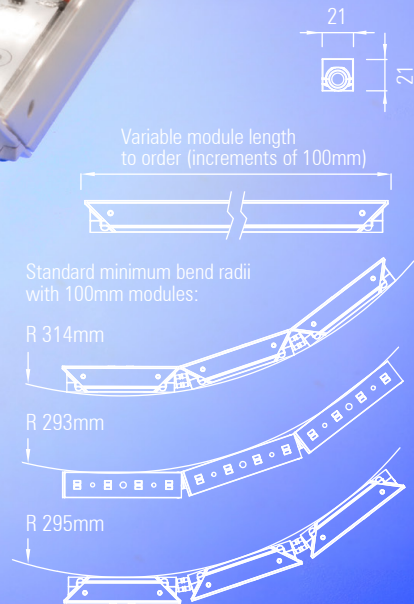

Up to 3,500 Lumens per mtr



Oriental Club, London.  
Lighting design by Victoria Jerram.

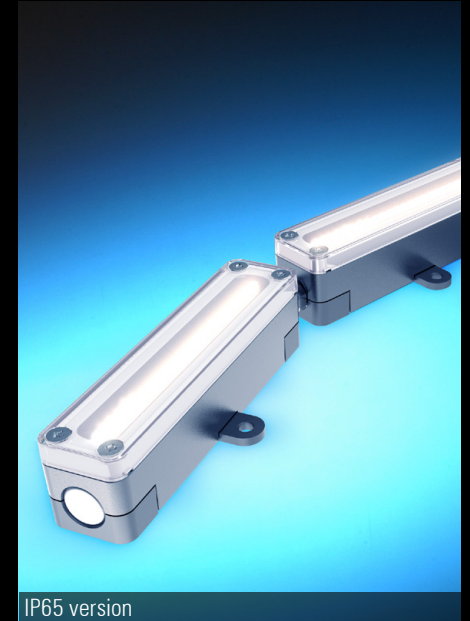

IP65 version

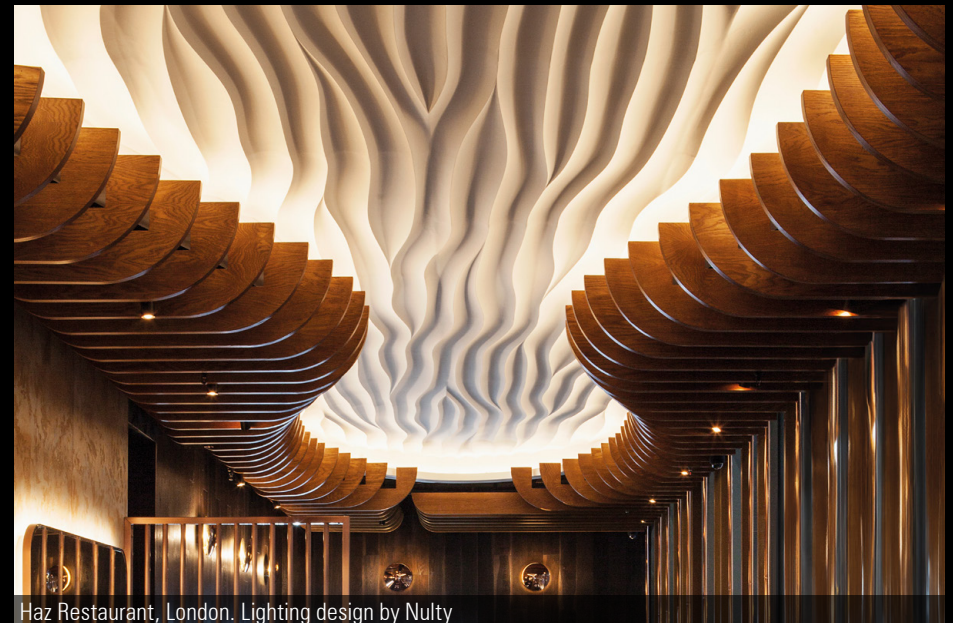

Haz Restaurant, London. Lighting design by Nulty

# Euclid 30 IP65

## Exterior LED linear lighting system

The Euclid 30 IP65 system can be used in a wide variety of exterior linear lighting applications including indirect cove lighting, wall grazing and wall washing.

The extruded body heat sink incorporates space for IP67 rated connectors so that up to 11 mtrs of the system can be linked together on site and fed from a single feed point without dark gaps.

The system incorporates the same medium power LEDs used in the interior Euclid systems. Up to 3,000 lumens per mtr. Opal, dot-free opal, clear window and linear lens versions are available. RGBW and dynamic white light engines can also be incorporated in this system.



Up to 3,000 Lumens per mtr

Euclid 30 IP65 with anti-glare cover accessory



Anti-glare cover accessory:



Adjustable angle bracket:

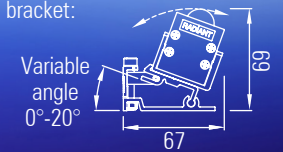

Variable length to order based on a 100mm module length

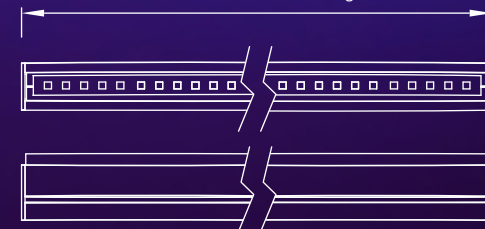

Fixed angle bracket

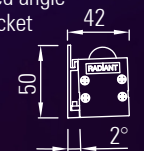

# Euclid 30 IP68

## Underwater IP68 LED linear lighting system

The Radiant Euclid 30 IP68 system is designed for use in underwater applications where linear lines of light are required. The system components are cast in 316 L stainless steel and are suitable for use in saline and chlorine environments, up to 2 mtrs in depth, including pools, fountains and marine projects.

The Euclid 30 modules incorporate the same LEDs and optics as the 3D LED Flex 25 IP68 so they can be used together on the same project. LEDs come in a wide variety of colour temperatures with CRI up to 95.

The system can produce up to 2,500 Lumens per mtr.



Up to 2,500 Lumens per mtr

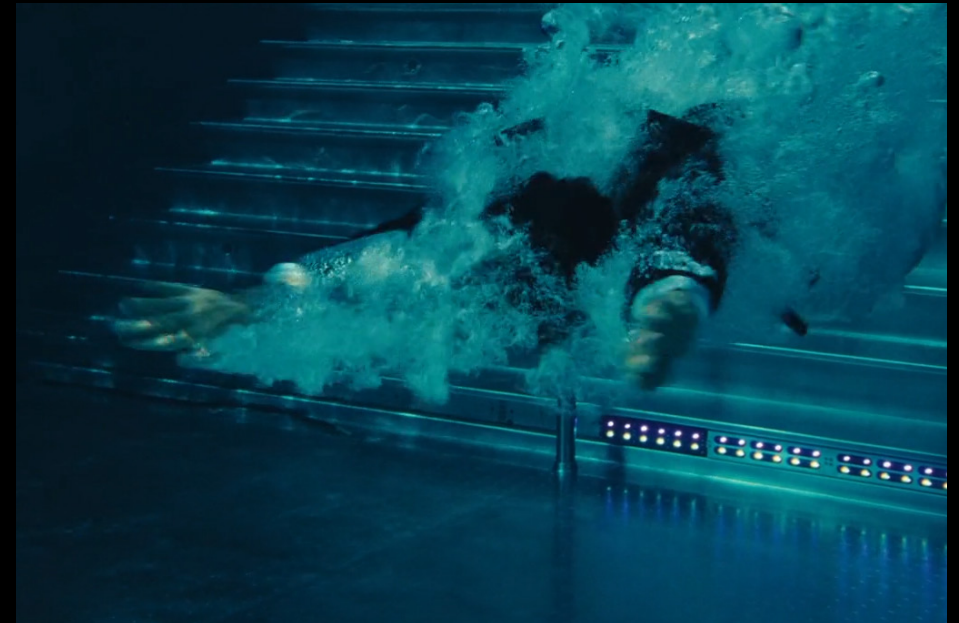

Sky Pool, Embassy Gardens, London. Lighting design by GIA Equation. Project photography by Ballymore

## Euclid 40 MP Standard and High Output IP20

### LED linear lighting system

The Euclid 40 MP system has been developed for use in a wide variety of linear indirect lighting applications and is optimized for cove lighting.

The system incorporates the same medium power LEDs used in the Shard and other Euclid systems so that they can all be used together in the same space.

Linear COB light engines can also be incorporated for use with specular lit surfaces.

The profile and light output of the Euclid 40 matches the non lens version of the 3D LED Flex 40 so that they can be used in the same project to light linear and curved spaces.

Up to 5,500 lumens per mtr. Clear or opal window versions are available along with RGBW and dynamic white light versions.

The system can be supplied in any length up to 2.5 mtrs with the smallest cutting module based on a 50 mm pitch.

On board linear drivers with a remote power supply and separate dimming channel.

A line voltage version is also available.

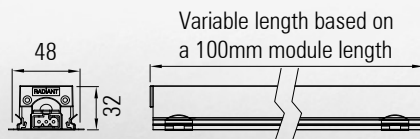

Up to 5,500 Lumens per mtr

## Euclid 40 IP20 with lenses

### LED linear lighting system

The Radiant Euclid 40 system has been developed for use in a wide variety of linear direct and accent lighting applications including wall grazing, and wall washing. Very narrow lenses provide excellent wall grazing over long distances.

The profile and light output of the Euclid 40 matches the lens version of the 3D LED Flex 40 so that they can be used in the same project to light linear and curved surfaces.

Anti-glare louvres from the 3D LED Flex 40 can also be used with the Euclid 40. Integral DC to DC LV drivers with a remote power supply, or a line voltage version is also available. The system can be supplied in any length up to 2.5 mtrs with the smallest cutting module based on a 100mm LED pitch.

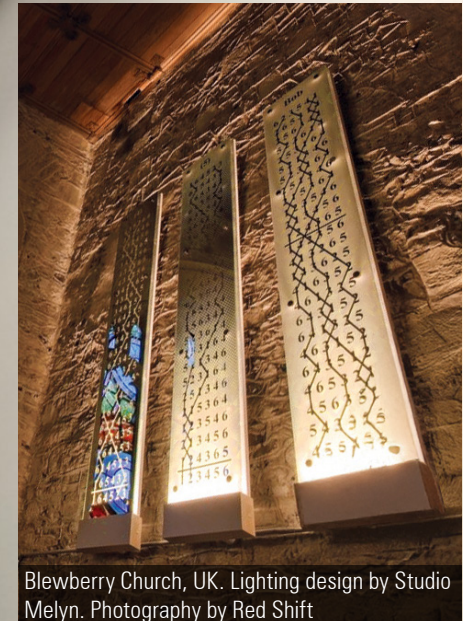
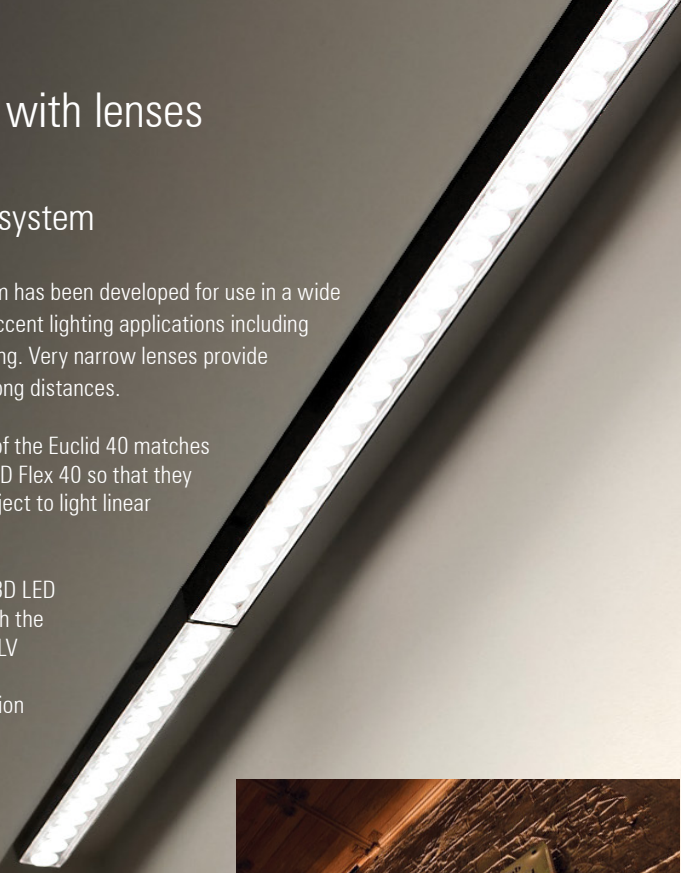

Blewberry Church, UK. Lighting design by Studio Melyn. Photography by Red Shift

# Euclid 40 Vector IP20

## Asymmetric LED linear lighting system

A custom designed asymmetric output version of the Euclid 40 was developed for the refurbishment of the David Geffen Hall at Lincoln Center for the Performing Arts in New York, in collaboration with lighting designers Fisher Marantz Stone.

In order to successfully illuminate the acoustically optimized undulating beech wood paneling of the auditorium walls luminaires with a strongly asymmetric output were required.

The custom Euclid 40 luminaires incorporate angled asymmetric lenses, anti glare louvres and a softening optical film to produce the optimal lit effect for the project.

Radiant self locking adjustable angle mounting brackets were included allowing vertical adjustment of individual luminaires.

Semi recessed and surface mounted versions of the luminaires were developed. All visible metal work was powder coated in a bespoke RAL powder coat, produced especially for the project, which matches the paint finish used for the project ensuring that the luminaires are as visually unobtrusive as possible.

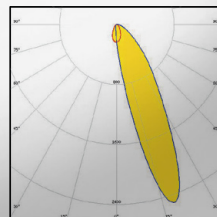

Up to 2,500 Lumens per 400mm luminaire



David Geffen Hall, New York, United States Lighting design by Fisher Marantz Stone

# Euclid 40 ERLE IP20

## LED linear lighting system optimised for the circular economy

The Euclid 40 WE ERLE System has a working life of up to 30 years due to its unique design, which allows for the Easily Replaceable Light Engines (ERLE) to be replaced without using specialist tools or requiring the system to be removed from its mounting location. The Radiant Euclid 40 system has been developed for use in a wide variety of linear direct and accent lighting applications including wall grazing, and wall washing.

A clamshell design clamps the aluminium core light engines to the heat sink with a cam action, ensuring excellent thermal management. Once the side panel is released by the locks and hinged open, the light engines can be easily accessed and unplugged from the wiring loom. New light engines can then be connected, pushed into position, and the hinged panel closed and locked.

TIR lenses are mounted to the LED board with spring clips, allowing them to be changed on-site, giving the ability to adjust the lit effect easily. The spring clip mounting also allows for easier recycling and reuse of the lenses. Remote drivers can be replaced at their end of life.



Custom length modules can be specified and the system can be configured for straight runs or as an articulated system for curved locations.



Easy on-site modifications to the lit effect by changing clip-mounted optics and LED boards.

System life of up to 30 years

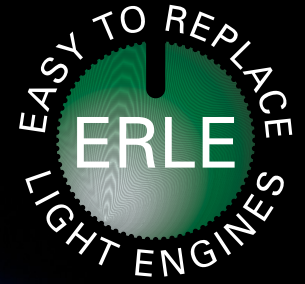
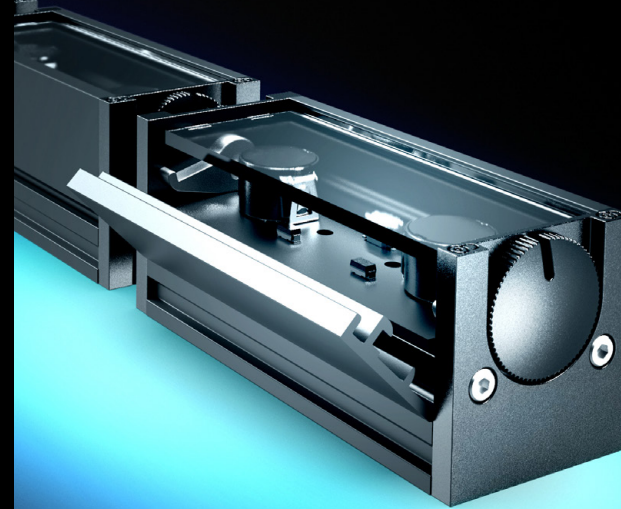

The catches at both ends of the luminaire can be turned using a flat-head screwdriver. The side panel is then able to hinge open, allowing access to the light engine, with the fixture remaining in situ.

Patent pending

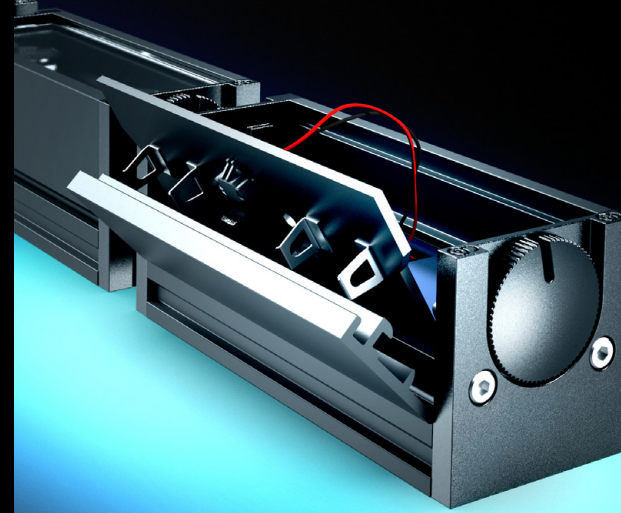

New light engines can then be connected, put in position, and the hinged panel closed and relocked. LED boards are clamped to the heatsink with a cam action - no fixing screws are required.

# Euclid 40 Standard and High Output IP65

## Exterior LED linear lighting system

The Euclid 40 IP65 system has been developed for use in exterior indirect linear lighting applications.

The system incorporates DC to DC linear constant current drivers to ensure efficient LED operation and so that long lengths of the system can be run from a single large power supply thus reducing wiring and installation costs. The Euclid 40 system can provide up to 5,000 lumens per mtr.

The extruded heat sink profile design allows end, side or back power entry. The LED pitch is maintained between the individual luminaires to maintain constant lighting levels without dark areas.

The system can be supplied in any length up to 2.5 mtrs with the smallest cutting module based on a 100mm LED pitch.

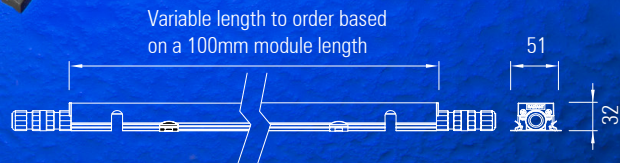
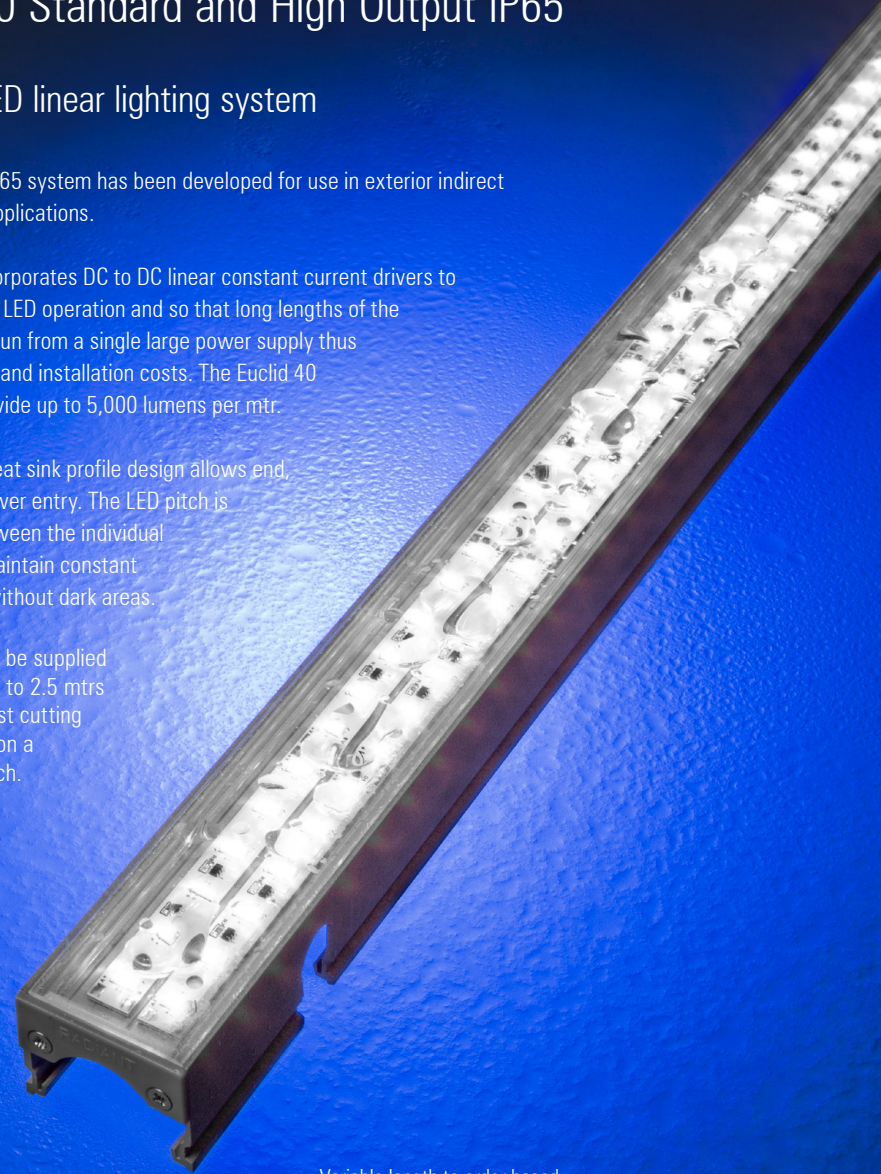

Up to 5,000 Lumens per mtr



Swindon Designer Outlet, UK. Architecture by McLaren & POD. Lighting design by Aecom

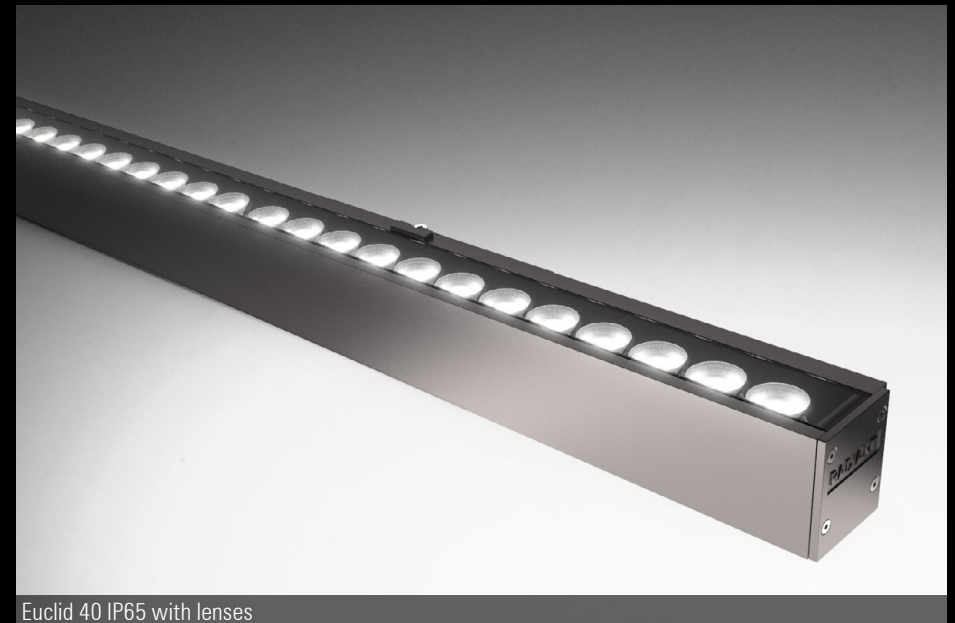

Euclid 40 IP65 with lenses

# Euclid 60 IP65

## Exterior LED linear lighting system

The Euclid 60 system has been developed for use in exterior linear lighting applications including wall grazing and wall washing. The system incorporates mains voltage dimmable drivers.

Side, back and end power feed options ensure continuous lighting without dark areas between luminaires.

The system can be supplied in custom lengths based on a 100 mm module up to 2.5 mtrs.

A variety of mounting bracket and glare control options are available including both micro and honeycomb louvres.

The system can be supplied in any RAL colour powder coat finish.

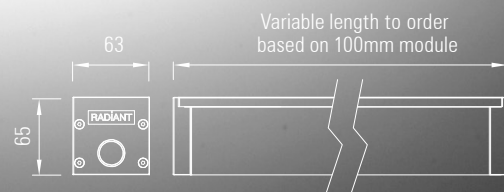

Up to 6,000 Lumens per mtr

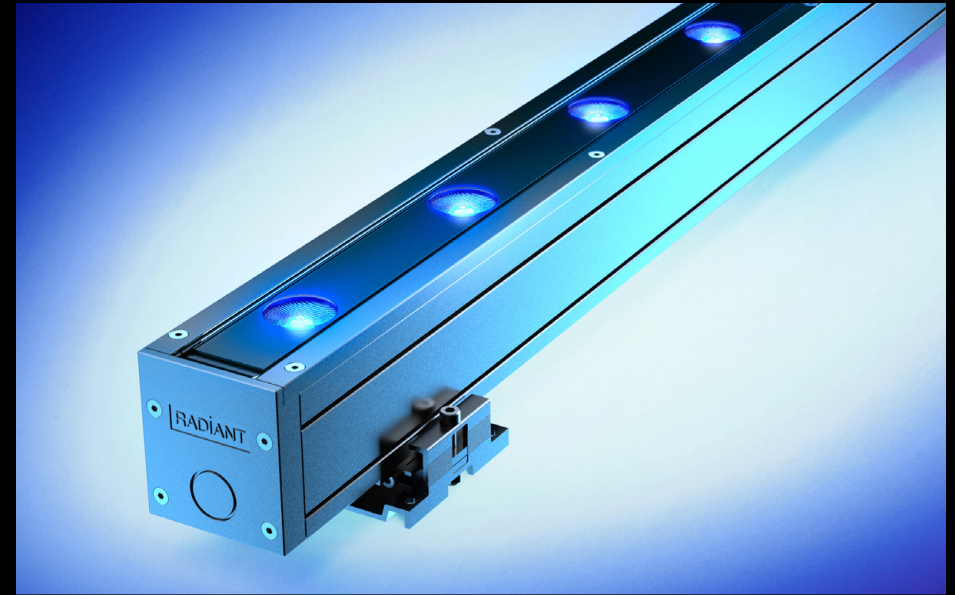

Euclid 60 IP65 RGBW with Gaggione's range of 32mm diameter colour-blending lenses



Euclid 60 IP65 with mid-power LEDs, linear lens and micro-louvre

# Euclid 60 In-Ground IP67

## Buried LED linear lighting system IP67

The Euclid 60 system has been developed for use in exterior wall grazing lighting applications. A high power optical system has been developed to produce an ultra narrow, dot free, line of light. Dark areas between luminaires are minimised with an innovative frame detail. A mid-power LED light engine with 3-ply opal diffuser is also available for wall washing applications. Anti-glare accessories are available.



The Exchange, UK. Lighting design by MBLD

Up to 6,000 Lumens per mtr

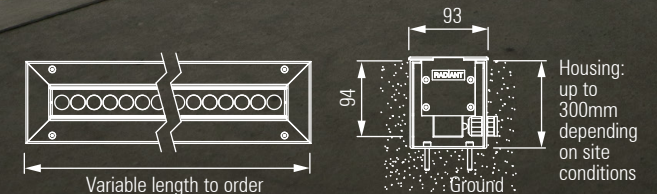

## Euclid 60 In-Ground IP67

### Buried LED linear lighting system IP67

A project specific version of the Euclid 60 system was designed in collaboration with MBLD for the Quay Club in Canary Wharf, London. Matching in-ground IP68 and ceiling-mounted downlight IP66 versions were created.

The LED linear lighting system comprises of a high-output LED light engine and a custom 3-ply opal diffuser, which runs from end to end, providing long seamless lines of light with no gaps between individual luminaires. Custom right-angle corner luminaires were also created - ensuring that the single unbroken seamless line of light was able to follow the entire perimeter of the atrium.

The luminaires are installed into the stainless steel housings and held in place with spring clips. There are no visible fixings once installed - allowing the system to integrate into the architecture as unobtrusively as possible. The stainless steel trim has a mirrored finish, to match the mirrored ceiling of the building.

Integral line voltage AC drivers allow for ease of wiring. IP68 connectors join the fixtures on-site and fit neatly within the housing.



Mid-power LED light engine



Exploded view

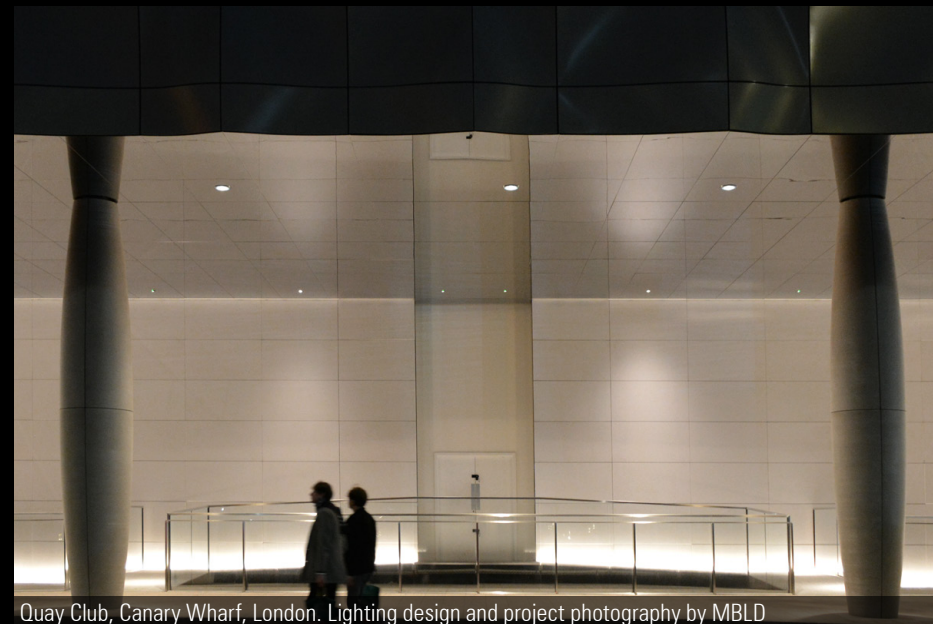
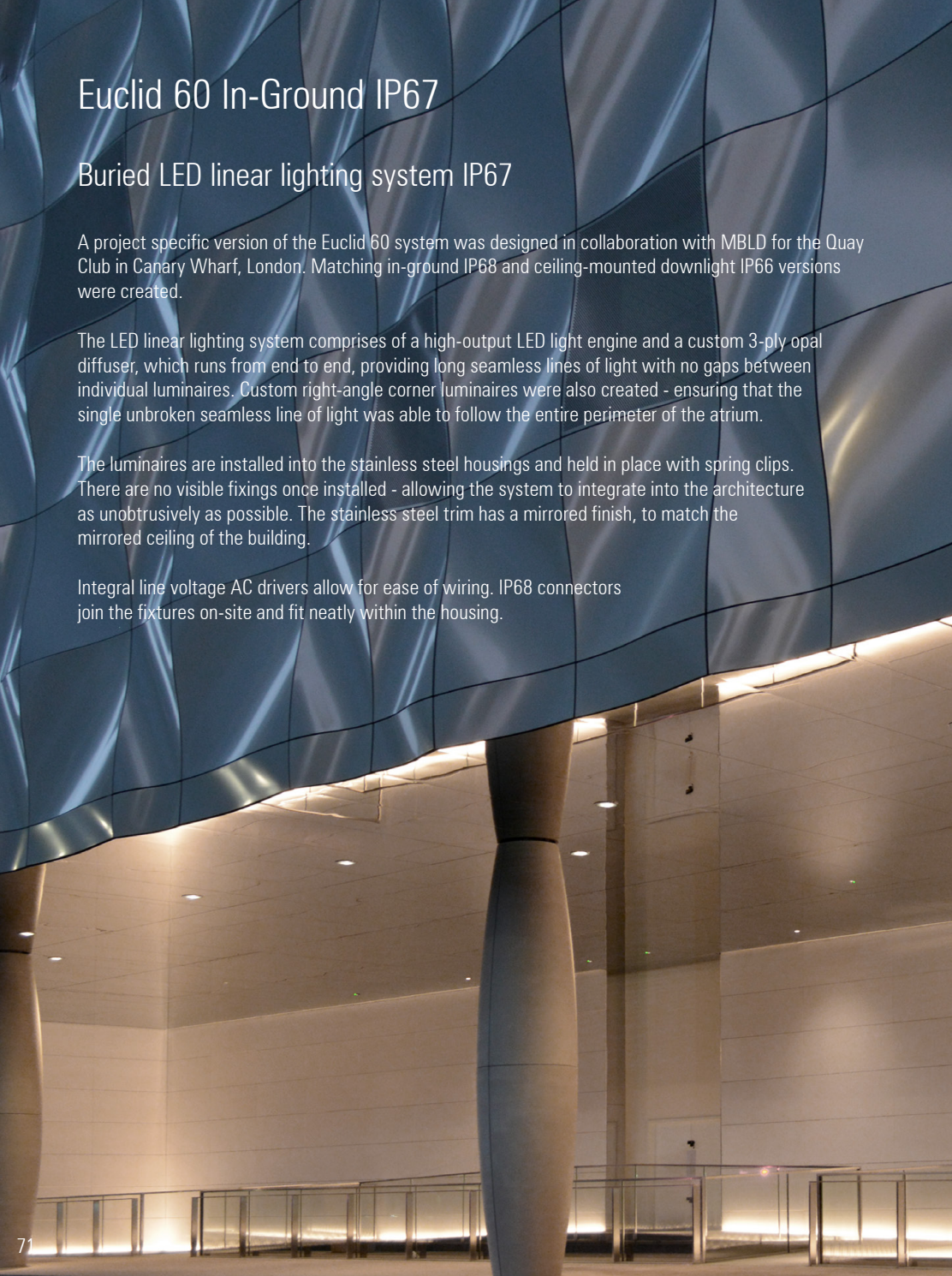

Quay Club, Canary Wharf, London. Lighting design and project photography by MBLD

## Euclid 80 IP65

### RGBW LED linear lighting system IP65

The Euclid 80 system has been developed for use in high power exterior linear RGBW architectural lighting applications including wall grazing and wall washing.

This system incorporates highly efficient colour blending Gaggione lenses giving high levels of RGBW, dynamic white or white LED output.

Integral or remote mains DMX / DALI drivers can be used.

The system can be supplied in custom lengths based on a 200 mm module up to 2.5 mtrs. A variety of mounting bracket and glare control options are available.

The Euclid 80 system can be supplied in any RAL colour powder coat finish.

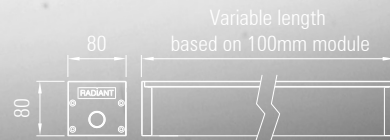

Up to 8,000 Lumens per mtr

## Euclid 80 IP67 In-Ground

### RGBW Buried LED linear lighting system IP67

The Euclid 80 system has been developed for use in high power exterior linear RGBW architectural lighting applications including wall grazing and wall washing.

The in-ground luminaires are installed into the stainless steel housings and held in place with spring clips. There are no visible fixings once installed - allowing the system to integrate into the architecture as unobtrusively as possible.

The RGBW light engine comprises a series of Luxeon Z LED clusters each with an elliptical beam colour-mixing lens. The light engines can be angled towards the surface being illuminated.

AC to DC constant current dimmable drivers are housed within the body of the fixture, allowing for ease of installation and wiring. IP68 connectors join the fixtures on-site and fit neatly within the housing.

Anti-glare accessories, including amicro-louvre, ensure excellent visual comfort.



# Euclid 100 IP65

## Exterior LED linear lighting system IP65

The Euclid 100 system is the most powerful linear system in the range and has been developed for use in exterior linear high output architectural lighting applications including wall grazing and wall washing.

This system incorporates 2 parallel light engines with optics. By combining elliptical and wider beam angle lenses in the same luminaire extremely tall facades can be evenly lit.

The system incorporates dimmable line voltage drivers.

The system can be supplied in custom lengths based on a 200 mm module up to 2.5 mtrs.



Up to 12,000 Lumens per mtr

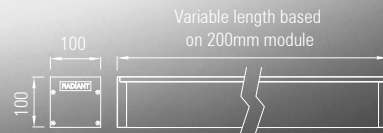

Newfoundland Tower, London



Lighting design by MBLD

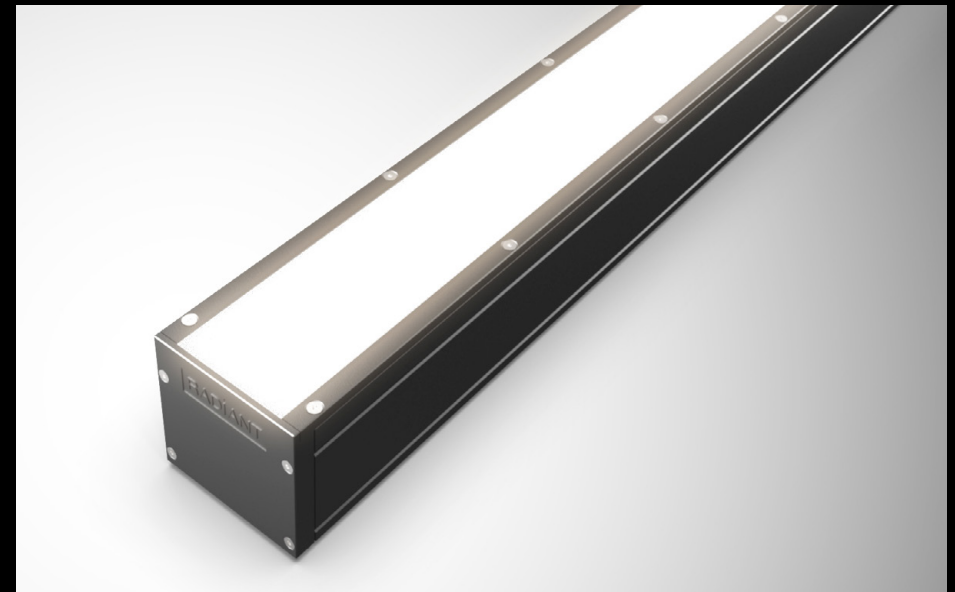

Euclid 100 IP65 with mid-power LED light engine and dot-free opal diffuser window

# Light Pipe IP20

## RGBW LED linear lighting tube system

The Light Pipe system was developed with our Swedish distributor Rebel Light as a custom design for an atrium lighting project in Stockholm.

Long runs of linked high power RGBW light engines illuminate the sections of frosted acrylic diffuser.

A structural spine heat sink incorporates plug and play cable management for the light engines for ease of installation and servicing.

The system can incorporate a wide variety of LED light engines with white, dynamic white or RGBW LED arrays.

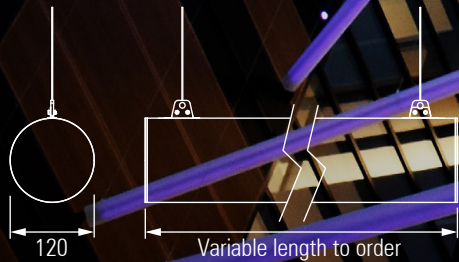

Telia headquarters, Sweden. Lighting design by ÅF Lighting

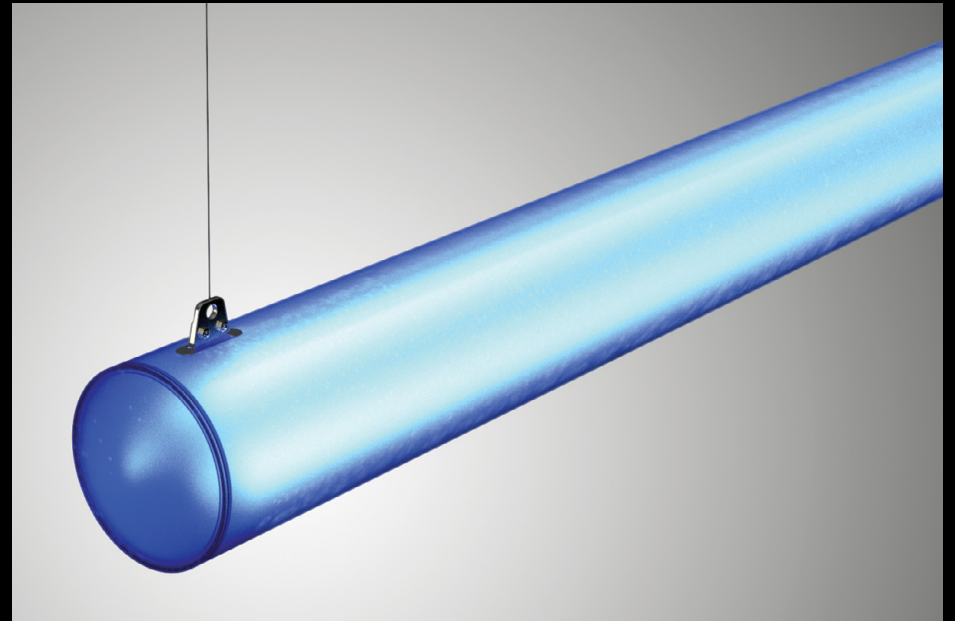

# Nano, Micro, & Macro Ribbed pendants IP20

## Interior optical LED pendant system

The Ribbed Pendant range incorporates the same optics and LV DC to DC dimmable drivers as the Micro Track and Aleta spotlight range so they can be used together in the same projects. Three diameters are available in custom lengths with any anodized or powder coat colour finish. A range of decorative cables are available. The ribbed pendants are designed for use in hospitality, retail, residential and architectural lighting applications. Gaggione colour-blending lenses can be incorporated into the Macro size, so that perfectly mixed RGBW and Tunable-white lighting effects with highly controlled beams, including an ultra-narrow beam option, can be created.

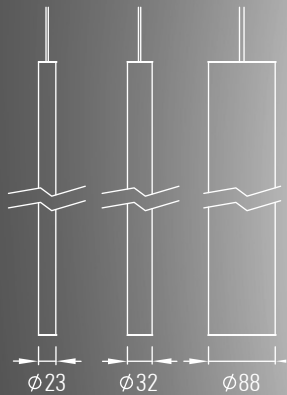

Macro Pendant: Up to 10 W  
Micro Pendant: Up to 7.5 W  
Nano Pendant: Up to 4.5 W



Exton park vineyard. Lighting design by OWL lighting

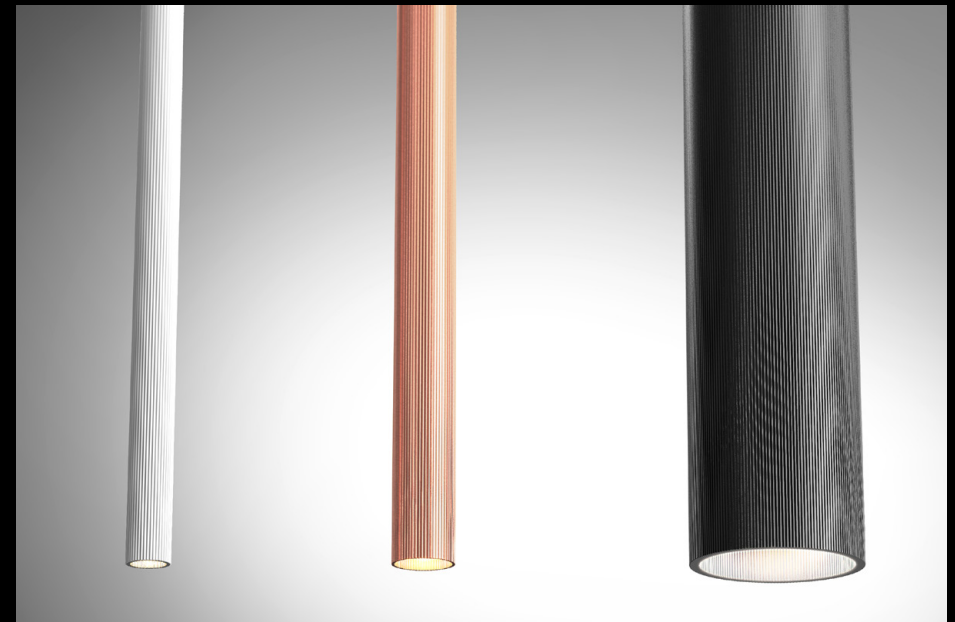

# Ovo pendant IP20

## Interior optical LED pendant system

The Ovo pendant is designed for use in retail, hospitality and residential projects.

A range of TIR optics allow for highly controllable directional accent lighting effects.

The customisable LED light engine can be run at up to 2W providing up to 250 Lumens. Dim to warm and very low colour temperature LED options are available.

Any anodized or RAL powder coat finish and a range of decorative cable options are available.

Pendants can be suspended from either Radiant's LV Micro Track or an individual surface mount base can be used.

The light output contains very little heat or UV making it ideal for the illumination of sensitive materials.

Up to 250 Lumens per pendant



# Micro Track System IP20

## Interior LV miniature track and spotlight system

The Radiant LED Micro Track is one of the smallest section low voltage track systems available and is designed for use in retail display, museums and residential lighting applications.

The range of dimmable miniature spotlights can be fitted with a wide range of anti-glare and light control accessories. MR16 spotlights are available with a range of magnetic snap-on accessories.

The light output from the Radiant LED spotlight range contains very little heat or UV. The system is ideal for the illumination of sensitive materials.



Nano Spotlight. Up to 2.5 Watts



Micro Spotlight. Up to 4.5 Watts

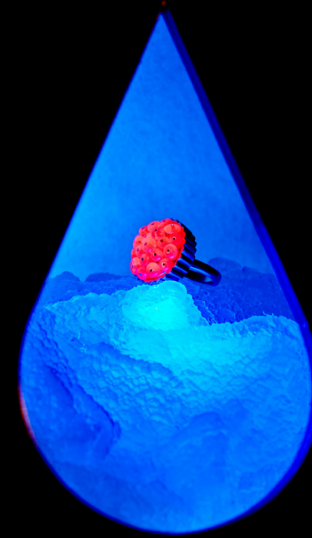

Louisa Guinness gallery, London. UV Nano Spots light Jewels with Fluorescence by Cora Sheibani



Harrods, London. Lighting design by BDP

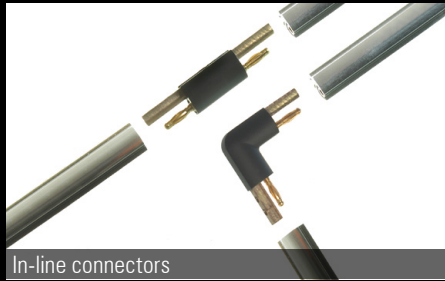

In-line connectors



Mini Spotlight. Up to 6.5 Watts



End cap and fixing clip with black and chrome



MR16 Spotlight. Up to 7.5 Watts

Snap MR16 holder

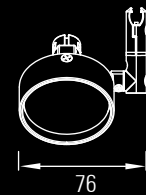

Mini Spotlight

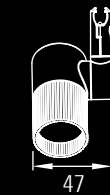

Micro Spotlight

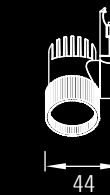

Nano Spotlight

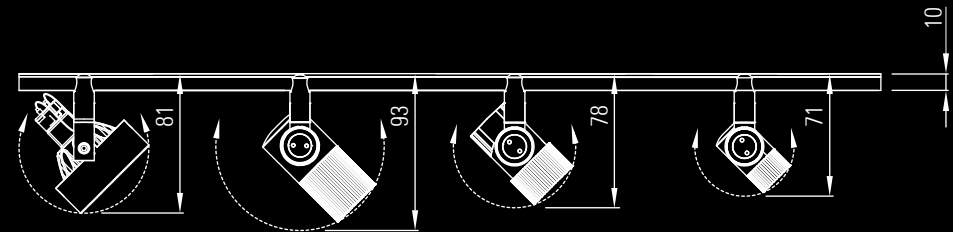
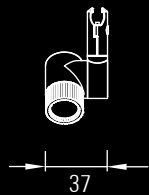

## D 100 and Aleta Projectors IP20

### LED projector range IP20

Radiant offers a versatile range of projectors for a wide range of interior applications.

The Aleta Projector range comes in 15W, 25W and 35 Watt versions and can be configured and customised to suit project requirements.

Integral driver and remote driver versions are available, with a wide range of light engines available.

Track mounted versions are available, including line-voltage Global track, and LV track options.



Aleta 25 Watt projector

## D 100 surface mount spotlight system IP20

### LED spotlight range IP20

The D 100 range was originally developed for use in the relighting of Hereford Cathedral in conjunction with Light Perceptions.

A low profile and excellent glare control were required for this project to ensure that the spotlights were as discreet as possible. There are integral and remote driver versions with one, or multiple spotlights per luminaire.

A wide variety of anti-glare, beam control and colour filter accessories are available. They are fully rotatable and lockable in both axes.



Global Track mounted D 100 Spotlight - line voltage system with separate dimming channel



Hereford Cathedral, UK. Lighting design by Light Perceptions

## D 100 IP20 Split RGB

LED spotlight range IP20 with separate RGB spotlights

A custom version of the D 100 Spotlight IP20 was designed in collaboration with Fabio A P Cristini at There's Light to create a triple colour shadow effect for the BLOK Shoreditch gym in London.

Three spotlight heads, each with different colour LEDs, are mounted to a driver box. Each one comprises 4 x high power LEDs with elliptical Ledil Tina lenses. They can be run at up to 11 Watts each.

Objects which are placed in front of them cast a 3 colour shadow onto the wall behind.

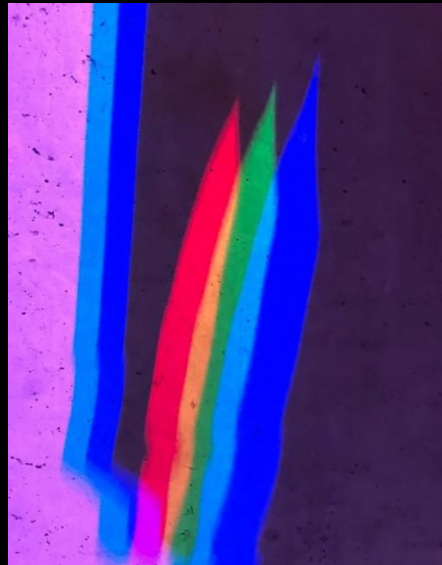

BLOK Shoreditch gym, London. Lighting design by Fabio A P Cristini at There's Light



## Stretta Projector System RGBW IP66

Exterior, DMX controlled, dynamic, 2 degree ultra-narrow beam, RGBW LED projector

The Stretta IP66 RGBW projector incorporates a 32x RGBW LED light engine, linear optic - producing a high intensity 1.5 ° x 35 °, ultra-narrow blade of light.

Two adjustable baffles allow the cut off angle to be fine tuned on-site.

The projectors are individually addressable via DMX, allowing for dynamic, customisable lighting effects to be achieved.

The projectors can be mounted onto a custom track system or surface mounted. The length and details of the track can be specified to suit project requirements. The projectors are rotatable in two axes using the adjustable angle brackets. Other mounting brackets are also available including custom designs to meet project requirements.

Different colour LEDs or white LEDs of different colour temperatures can be specified for each of the 32x LEDs within the light engine.

Each projector can be run at up to 50 Watts.

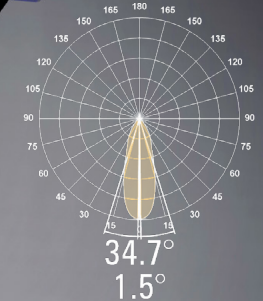
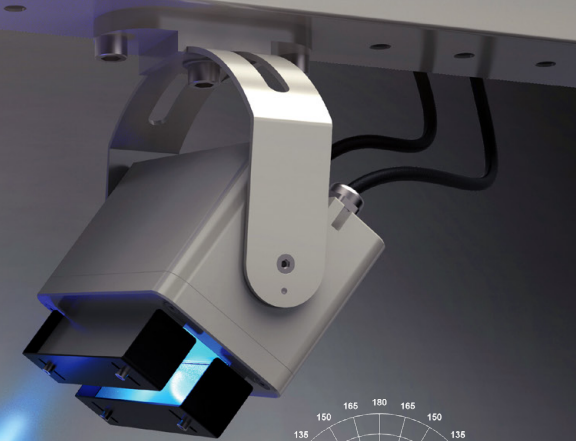
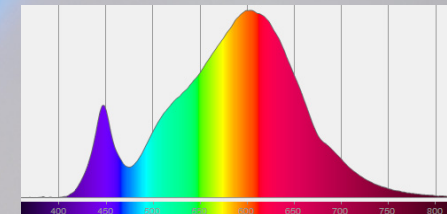

'Nexus' Light Art installation, UK. Lighting design by MBLD and project photography © MBLD

## Micro spotlight system IP65

### Miniature exterior optical LED spotlight system

The IP65 Micro Spotlight range has been developed for use in landscape and garden lighting applications where miniature, highly controlled lighting effects are required. Each spotlight has a 3.5 Watt LED light engine with an integral LV DC to DC driver. The spotlights are run from a remote 12 V DC power supply.

A wide variety of mounting accessories including ground-spikes and tree-straps can be specified to suit project requirements. Customisable glare control accessories are also available for this system.



Up to 300 Lumens per spotlight



# D 100 IP66

## LED accent lighting range IP66

The Radiant D 100 system has been developed for use in a wide variety of exterior architectural lighting projects requiring highly controlled accent lighting effects from a compact luminaire. The D 100 can operate up to 10 Watts of LEDs, giving a light output of up to 1,000 Lumens. Various LED types and optic configurations are available including RGBW, RGBA and Tunable-white light options. Gaggione's ultra-narrow beam colour-blending lens provides a 6 degree beam when used in conjunction with a cluster array of RGBW or Tunable-white LEDs. Integral LV DC to DC driver and remote AC to DC driver versions are available. A variety of mounting options and anti-glare accessories are also available, making this a highly versatile system.



Ultra Narrow 3 degree beam lens



RGBW or Tuneable-White with ultra-narrow 6 degree beam lens

Arnhem, Netherlands. Lighting design and project photography by Atelier LEK

Custom versions of the D 100 IP66 spotlight system were created in collaboration with Atelier Lek for the master lighting renovation project for the city of Arnhem in Holland. Custom bracketry allow the spotlights to be mechanically integrated into the masts, which were designed and commissioned by Atelier Lek specifically for this project. The brackets allow the spotlights to be rotated and aimed, whilst maintaining a compact form factor. The spotlights comprise of a high power LED light engine with a narrow beam Gaggione lens, which provides highly controlled accent lighting used to illuminate the historic former Post Office building and other architectural highlights around the city centre. Each spotlight can be run at up to 10 Watts, providing up to 1,000 lumens.

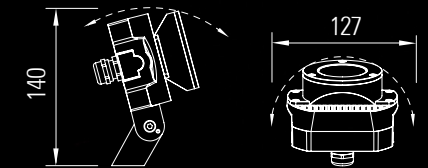
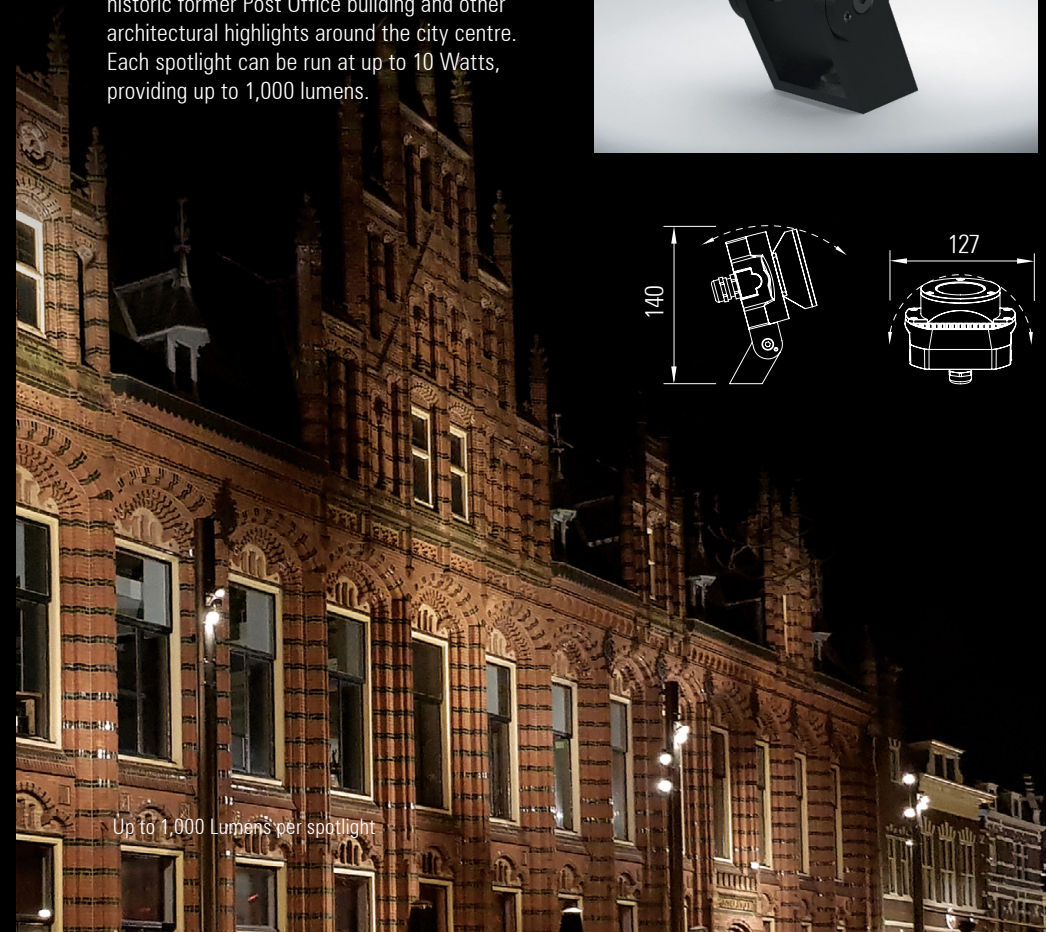

Up to 1,000 Lumens per spotlight

## D 40 IP66

### LED accent lighting range IP66

The Radiant D 40 system has been developed for use in a wide variety of exterior architectural lighting projects requiring highly controlled accent lighting effects from a compact luminaire. The D 40 can operate up to 5 Watts of LEDs, giving a light output of up to 500 Lumens. Various LED types and optic configurations are available including RGBW, RGBA and Tunable-white light options. An ultra narrow beam lens can produce a 4° beam. Integral LV DC to DC driver and remote AC to DC driver versions are available. A variety of mounting options and anti-glare accessories are also available, making this a highly versatile system.



Strasbourg Cathedral, France. Lighting design by Acté Lumière. Dare Award Winner - Structures. Best Exterior Lighting Scheme, High Budget

[d]arc awards  
WINNER

# Centura module IP20

## LED accent lighting range IP20

The Radiant Centura module IP20 system has been developed for use in a wide variety of architectural lighting projects requiring highly controlled accent lighting effects from a compact luminaire. The Centura module system can be used as wall-lights with up light, down light or up and down light options. Opal diffuser for ambient lighting, or lensed options for wall grazing can create the perfect lit effect to meet the project requirements. The Centura 40 module, which is 100mm in length, or the longer Centura 40 150 module, which is 150mm in length, have a slim profile of 40mm. The larger 60mm wide Centura 60 module, which is 100mm in length, can be specified for projects which require a 50mm diameter Gaggione colour-blending lens, which provide efficiently blended RGBW and Tunable-white outputs in a range of beam angles, including ultra-narrow beam and narrow-elliptical beam options. Centura modules can also be specified as downlight ceiling mounted fixtures.

The Centura 40 150 module system can operate up to 7.5 Watts of LEDs per module, giving a light output of up to 800 Lumens. Various LED types and optic configurations are available. Integral LV DC to DC driver and remote AC to DC driver versions are available. Any colour RAL powder coat finish can be specified. Custom mounting solutions can be specified.

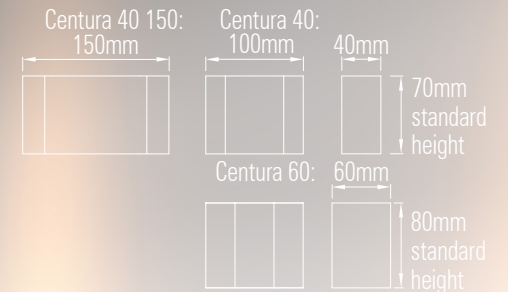
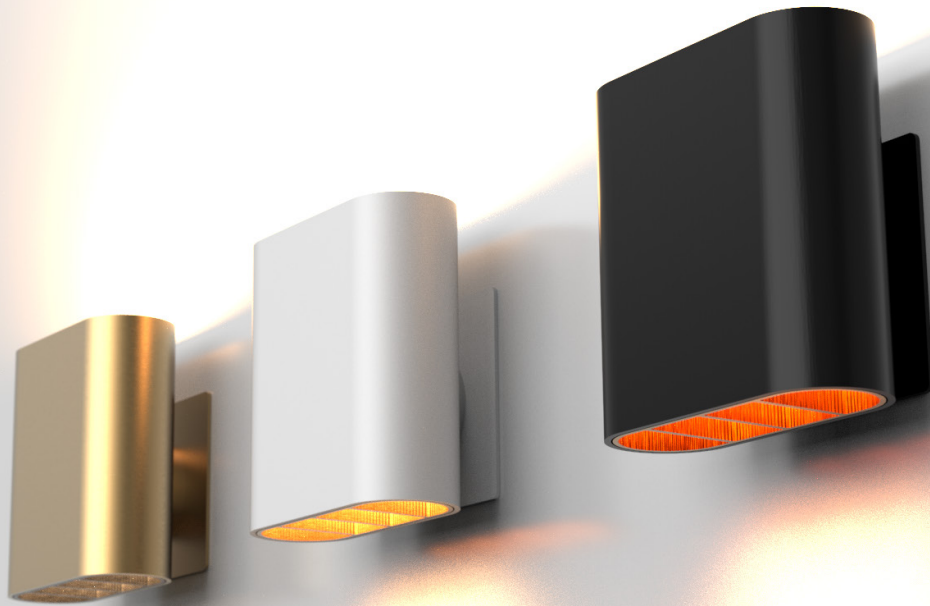

Up to 800 Lumens per module

# Water Effect Lighting system

DMX controlled, dynamic LED effect light, IP20 and IP65

The Water Effect system was developed with ÅF Lighting for the Landmarket residential tower block project in Stockholm.

The surface mounted luminaires create a slowly changing effect of light reflected from flowing water.

A wide range of LED colour temperatures and coloured LED options can be incorporated in this system. Combining multiple LEDs with different textured glass panels and a 4 channel DMX controller creates unique lighting effects which can be customized for each project.

Light output up to 1,900 lumens with all LEDs on full power.

The system is available in IP20 and IP65 versions and the enclosures can be powder coated in any RAL finish.

There are currently two sizes available: a 150mm length version and a 300mm length version.

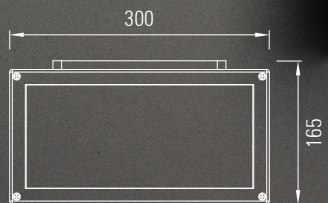
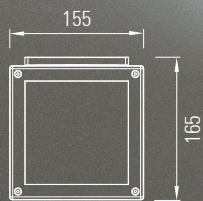

Low embodied carbon version with an enclosure made from European Oak



Landmärket residential tower, Stockholm. Luminaire concept and lighting design by ÅF Lighting

# Water Effect In-ground RAD 250 WE and RAD 180 WE

DMX controlled, dynamic LED effect light, IP20, IP66 and IP67

The in-ground version of the Water Effect system has developed the concept to a higher power level with multiple groups of LEDs and DMX control channels. Combining a variety of LED colour temperatures and colours with textured glass and complex dimming sequences creates abstract light patterns that can be customized for each project. The luminaires are durable with a walk over rated glass window, provide up to 3,500 lumens and as there are no moving parts, will provide a long working life. 255 mm and 180 mm diameter luminaires are available with a depth of only 100 mm for some versions.

MBLD specified Radiant's Water Effect system to provide dynamic effect lighting for the W Algarve in Portugal. The LED sequence, controlled by the integral DMX controller, along with the light engines and decorative textured glass, were all tailored to achieve the perfect lit effect for each area of the project. The luminaire comprises a durable walk-over rated glass window, a stainless steel bezel, and a buried housing which contains the DMX controller, light engine and textured glass. The system is IP67 rated.

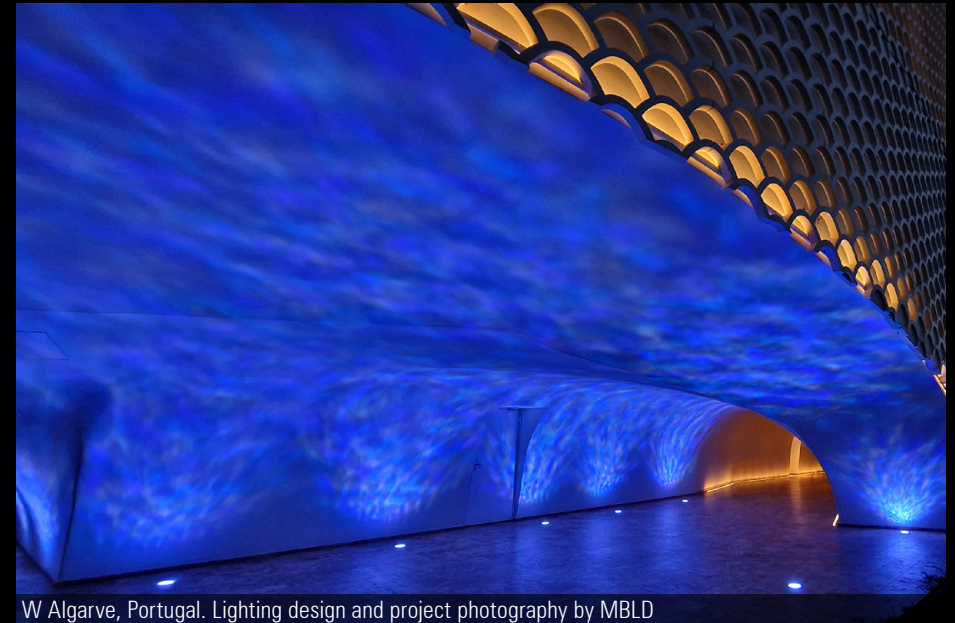
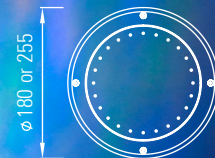

W Algarve, Portugal. Lighting design and project photography by MBLD



# Euclid 40 WE System IP20

Interior, linear, DMX controlled, dynamic LED effect lighting system

The Euclid 40 WE IP20 System is a linear, DMX controlled, dynamic LED effect lighting system, designed for use in interior architectural lighting applications.

Decorative, dynamic lit-effects are achieved using a combination of an LED matrix of various colour temperatures and colours, complex DMX controlled dimming sequences, and textured glass optics.

As the dynamic lit-effect does not rely on any moving parts, the system has a long working life of up to 100,000 hours, as the LEDs are not run at full output for most of the dimming sequence.

Custom lit-effects can be achieved to suit project requirements by modifying the DMX controlled LED sequences, the combination of LEDs specified and the type of textured glass optic used.

Anti-glare accessories including snoots are available to minimise glare.

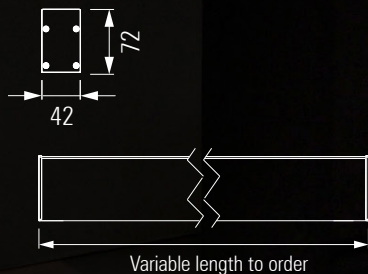

Flexible linear ball-joint configuration

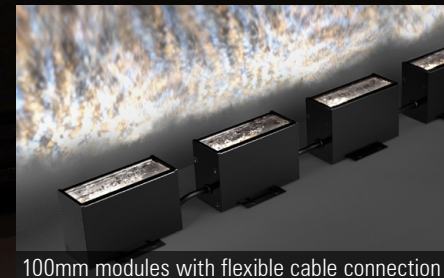

100mm modules with flexible cable connection

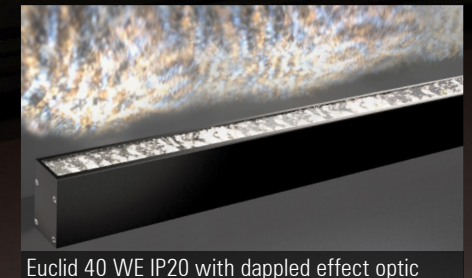

Euclid 40 WE IP20 with dappled effect optic

# Euclid 40 WE ERLE System IP20

Interior, linear, DMX controlled, dynamic LED effect lighting system optimised for the circular economy

The idea behind the development of the Euclid 40 WE ERLE System is to extend the working life up to 30 years by making the light engines easy to replace on site.

The Easily Replaceable Light Engines (ERLE) can be replaced without using specialist tools or requiring the system to be removed from its mounting location. Keeping the lighting system in use for an extended period of time is one of the most effective ways to reduce the overall carbon footprint of this type of system.

A clamshell design clamps the aluminium core light engines to the heat sink with a cam action, ensuring excellent thermal management, allowing them to be easily removed and replaced.

Once the extruded side panel is released by the locks and hinged open the light engines can be easily accessed and unplugged from the wiring loom. New light engines can then be connected to the system wiring, pushed into position and the hinged panel closed and locked, with the fixture remaining in situ.

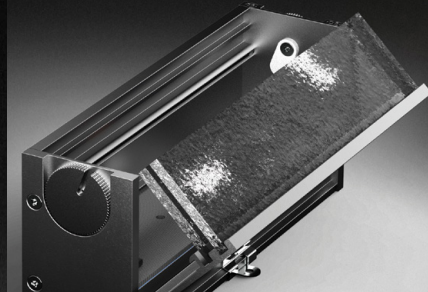
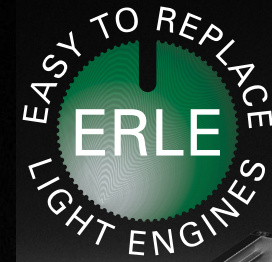

With the side panel open, the glass optics can be swapped out. The lit effect can be updated by changing the textured glass optics.



The clamshell design clamps the aluminium core LED boards to the heat sink, ensuring excellent thermal management.

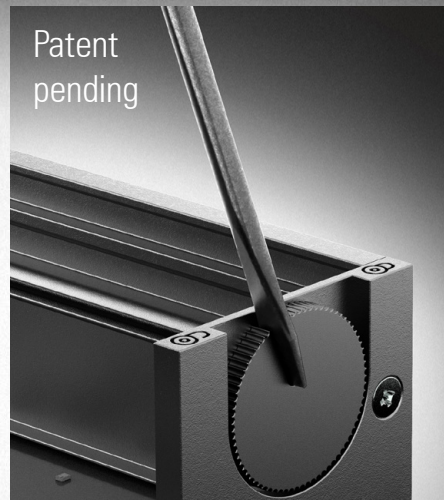
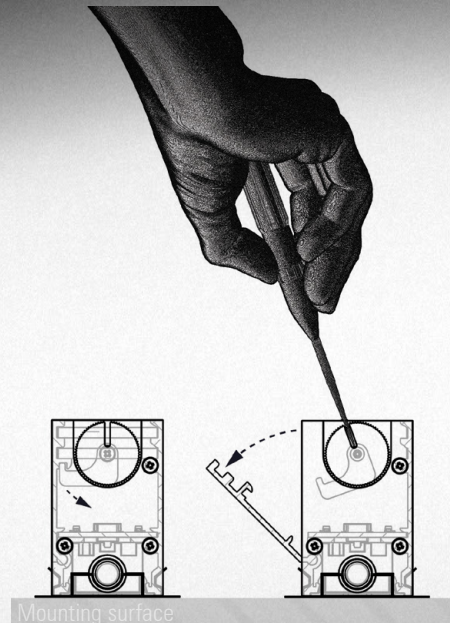

The catches at both ends of the luminaire can be turned using a flat-head screwdriver. This rotates the internal cam latches - releasing the side panel, which is then able to hinge open.



Once released, a qualified technician will then be able to access the LED board and wiring loom - replacing the LED boards if necessary.



## Euclid 60 WE System IP65

Exterior, linear, DMX controlled,  
dynamic LED effect lighting  
system

The Euclid 60 WE IP65 System is a linear, DMX controlled, dynamic, LED effect-lighting system, designed for exterior architectural and landscape lighting applications. As with all of Radiant's Water Effect Systems, there are no motorized components and the dynamic lit effect is controlled by the DMX dimming sequence. Customised lit effects can be tailored to suit project requirements. The system can provide up to 3,000 lumens per mtr.



## Colour Ray System

DMX controlled, dynamic LED  
effect light, IP20, IP66 and IP67

The Colour Ray - surface mount and linear in-ground version is a DMX-controlled dynamic effect lighting system that creates gently changing sequences of colour light rays.

The light-engine comprises of a DMX- controlled matrix of coloured LEDs with optics. The light passes through a lattice structure of chromed bars, creating a decorative polychrome prismatic effect, fluctuating with the dynamic LED dimming sequence. The lit-effect can be customised to suit project requirements.

The system can be supplied for use in interior indirect cove lighting applications in an IP20 enclosure or in an IP rated enclosure for exterior wall washing.



W Algarve, Portugal. Lighting design by MBLD

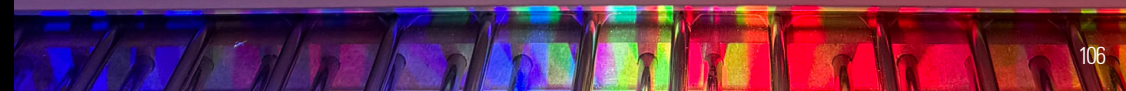
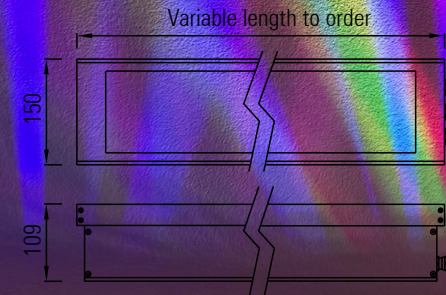

## 3D LED Flex 40 WE System IP20

Interior, 3D Flexible, DMX controlled, dynamic LED effect lighting system

The 3D LED Flex 40 WE System IP 20 combines the dynamic effect-lighting approach developed for our Water Effect range with the 3D flexible, modular, linear format of our 3D LED Flex systems, incorporating a patented ball-joint system linking the modules.

The 100mm modules are linked by an articulated ball-joint system, which allows the system to bend and twist in 3 dimensions - allowing it to follow complex curved architectural profiles. The system is hand-bendable on-site and the adjustable angle brackets allow for the lit effect to be aimed and locked once installed.



## D 100 WE System IP20 and IP66

DMX controlled, dynamic LED effect lighting projector system

The D 100 WE LED effect-lighting projectors, have been developed for use in landscape and architectural lighting applications which require customisable, decorative, dynamic lit-effects from a compact luminaire. They are suitable for indoor and outdoor applications.

Like all of Radiant's Water Effect Systems, customisable, decorative, dynamic lit-effects are achieved with an LED matrix of various colour-temperatures and colours, complex DMX controlled dimming-sequences, and textured-glass optics.



Somewhere by Nico, Glasgow. Lighting design by Mistry Lighting

## D 200 WE System IP20 and IP66

### DMX controlled, dynamic LED effect lighting projector system

The D 200 WE is an LED effect-lighting projector system, developed for use in landscape and architectural lighting applications which require customisable, decorative, dynamic lit-effects from a compact luminaire. They are suitable for indoor and outdoor applications.

Each fixture incorporates a 16x LED light engine, one or two LV multi-channel DMX drivers and a textured glass panel optic. These can all be customised to create decorative, dynamic lit-effects tailored to suit project requirements.

The system does not rely on any moving parts and the LEDs are not run at full power for most of the dimming sequence, giving a long working life of up to 100,000 hours.

Each fixture can be run at up to 20 Watts, providing up to 1,600 lumens, depending on the mix of LED colours and colour temperatures and the textured glass used. The lumen output varies during the dimming control sequence.

Rotatable in two axes using the adjustable angle brackets. Other mounting brackets are also available including custom designs to meet project requirements. Tree-strap and ground spike mounting options are available.

Both integral DMX LV driver and remote AC to DC DMX driver versions are available.

Various LED colours, colour temperatures and CRI options available. Different colour LEDs or white LEDs of different colour temperatures can be specified for each of the 16 LEDs within the light engine.

Custom anti-glare accessories can be specified - ensuring excellent visual comfort. Satin black, satin white or any RAL paint colour finish.



# RADIANT<sup>®</sup>

ARCHITECTURAL LIGHTING

Radiant Architectural Lighting Limited  
10 Broadbent Close  
20 - 22 Highgate High Street  
London N6 5JW  
ENGLAND UK

TEL + 44 ( 0 ) 20 8348 9003

E MAIL [enquiries@radiantlights.co.uk](mailto:enquiries@radiantlights.co.uk)

WEB [www.radiantlights.co.uk](http://www.radiantlights.co.uk)

For updates about our latest products, projects  
and other news, follow us on social media:

